



**KIND 4 stores**

pure shopfitting

**KENIG | HARRES | OTTOKIND | ZOK**

SHOPFITTING SYSTEM

# FRUIT & VEGETABLES



Ideally positioned in the fresh produce marketplace



**KIND 4 stores**  
pure shopfitting

# FRUIT & VEGETABLES





## Shopfitting excellence

This is shopfitting with **KIND4stores**: strong design and the final touch in practical implementation. For all kinds of product ranges, small shops and large stores, food and non-food. From the smallest space to the biggest sales floor. Whether standard components or bespoke designs, we'll find the solution for you!

Our primary goal is to guide our retail customers to success in their business. Many of them have been fitting out their shops with our trend-setting solutions for decades. Most **KIND4stores** products are made in Germany, the rest in Central Europe. This means short distances and reliable planning, which are more important today than ever before.

Since 2023, **KIND4stores** has been busy merging the shopfitting activities of König Object Consulting, HARRES Metall-design, Otto Kind and ZOK-system. Under the umbrella of NWI (Frankfurt), the shopfitting group brings together planning expertise, modular shopfitting systems, customised furniture construction and high production capacities made in Germany.

[www.KIND4stores.com](http://www.KIND4stores.com)

# Fruit & vegetables at their very best



The fresh produce department is the flagship in the food retail business. It is here that customers look around very attentively – and yet allow themselves to be tempted by an attractive and varied display of fresh goods.

As shopfitting specialists, the **KIND4stores** team knows from experience why it pays off to excel and stand out among your competitors especially in this department: the fresh produce department has long since become a major USP!





### **Boosting sales with freshness ambassadors**

For consumers, fresh produce expertise is one of the key criteria when choosing their market. Among the groups of fresh goods, the fruit and vegetables sales area is clearly at the top of the grading scale, even ahead of the meat department.

*“This is my favourite market. The fruit and vegetables department is simply wonderful.”*

It goes without saying that customers expect the produce to be freshly picked, delicious, and as natural as it comes. But it isn't just the goods that have to make customers' taste buds tingle, it's also how they are presented. That's why an attractive fresh produce department with a pleasant shopping atmosphere can make a decisive contribution to boosting sales significantly.

Consumers who are satisfied with what a store has to offer in the way of fresh goods spend considerably more money there than customers who aren't impressed by it!



# Professional furnishing solutions for your

With our **KIND4stores** shopfitting brand we create solutions for retailers to present their fruit & vegetables products at their very best. They aim to make your customers' shopping

- as easy and convenient as possible,
- an outstanding experience
- a reliable source of information.

## Why you will always get the cherry on the top with us

When it comes to the design and manufacturing of shelving systems we can draw on decades of experience.

We manufacture our **KIND4stores** quality products at our own facilities in Germany, subject to external audits and continuous quality checks. Our portfolio ranges from standardised and scalable shopfitting systems to individual and bespoke shop and store solutions. Our customers include discounters as well as premium supermarkets and self-service hypermarkets.



# flagship department







# Starring fruit & vegetables

We have designed our fruit & vegetable solutions to keep the actual display unit with its unobtrusive and high-quality design in the background. Instead, the stage belongs to an abundant variety of juicy fruit, crispy salads and fresh vegetables – a colourful feast for the eye designed for full effect.

Slim constructions ensure that a maximum of goods can be arranged in a minimum of space. This gives the impression that there are fruit and vegetables aplenty, effectively increasing sales impact. Carefully selected decorative elements set the right visual accents to individualise and adapt the shelving system.

## Customer experience in fresh produce paradise

First of all, have your customers slow down, stimulate their senses, set their mood for pleasure... The fresh produce department is where the customer route typically starts and the course is set for the entire shopping journey.

This makes it all the more important to create a pleasant atmosphere, for instance by state-of-the-art lighting technology, coordinated colours and materials, ceiling canopies, acoustic walls etc.

All these details build the foundation of narratives and create the ambience that stages fruit and vegetables, enabling them to arouse emotions.



# A world of flavours: from regional to exotic



A conscious and healthy diet, natural food and regional shopping are consumer trends that will continue to gain in significance. An increasing number of people prefer seasonal produce, harvested in the region when ripe and transported a short distance from producer to consumer. Even those who don't buy exclusively organic food want to know the origin of the pears, berries, cabbage and potatoes on display. A lot of customers are even keen to know the agricultural producer, just like when going to the weekly market, where people prefer to buy from their trusted market stall.

We help you bring the weekly market success story to your sales area: with stories and images of country-style farmer's markets with organic potatoes, fresh asparagus and ripe seasonal fruit, supplemented by cross-selling products such as honey – all regional produce.

Of course, there are other ways of staging fresh produce: for instance, a Provençal market with oxheart tomatoes, sun-ripened apricots, fresh herbs, olive oil and lavender. Or – something completely different – a noble fresh produce palace with fine vegetables and exotic fruit, inspired by haute cuisine.

We look forward to assisting you with your own storytelling – adapted to your product range and customer preferences.





## Well informed

“Where can I find...?” Most questions from customers refer to the specific products they are searching for. Organise your fruit and vegetables – with the **KIND4stores** shelving system. A neatly structured range of products laid out clearly, for instance by product group, and informative labelling helps customers find their way. Every customer who knows where to find what they have on their shopping list unburdens the technical staff who can then focus fully on recommending what to purchase and give advice where it is really needed.





**FROM  
SHELF  
TO TABLE  
AS IF  
FRESHLY  
HARVESTED!**

# The multifunctional furnishing system that suits

A special benefit of the **KIND4stores** shelving system for fruit & vegetables is its special flexibility.

Thanks to its modular design tailored to the needs of the fresh produce department, our solution can be adapted easily to the specific prerequisites of your store and made to fit perfectly. The outstanding variability allows for virtually all directions of customer routing with external wall shelves and freestanding gondola shelving units. Our product range has even more advantages: it can be reconfigured quickly and is easily enlarged with additional components.



The **KIND4stores** solution ensures the highly efficient placement of products and provides the best prerequisites for additionally implementing current consumer trends and customer needs: e.g. themed displays such as local specialities, the presentation of high-margin convenience products such as fresh cuts and smoothies, promotional areas for sample tasting, service zones such as asparagus peeling stations, etc.



# virtually all requirements

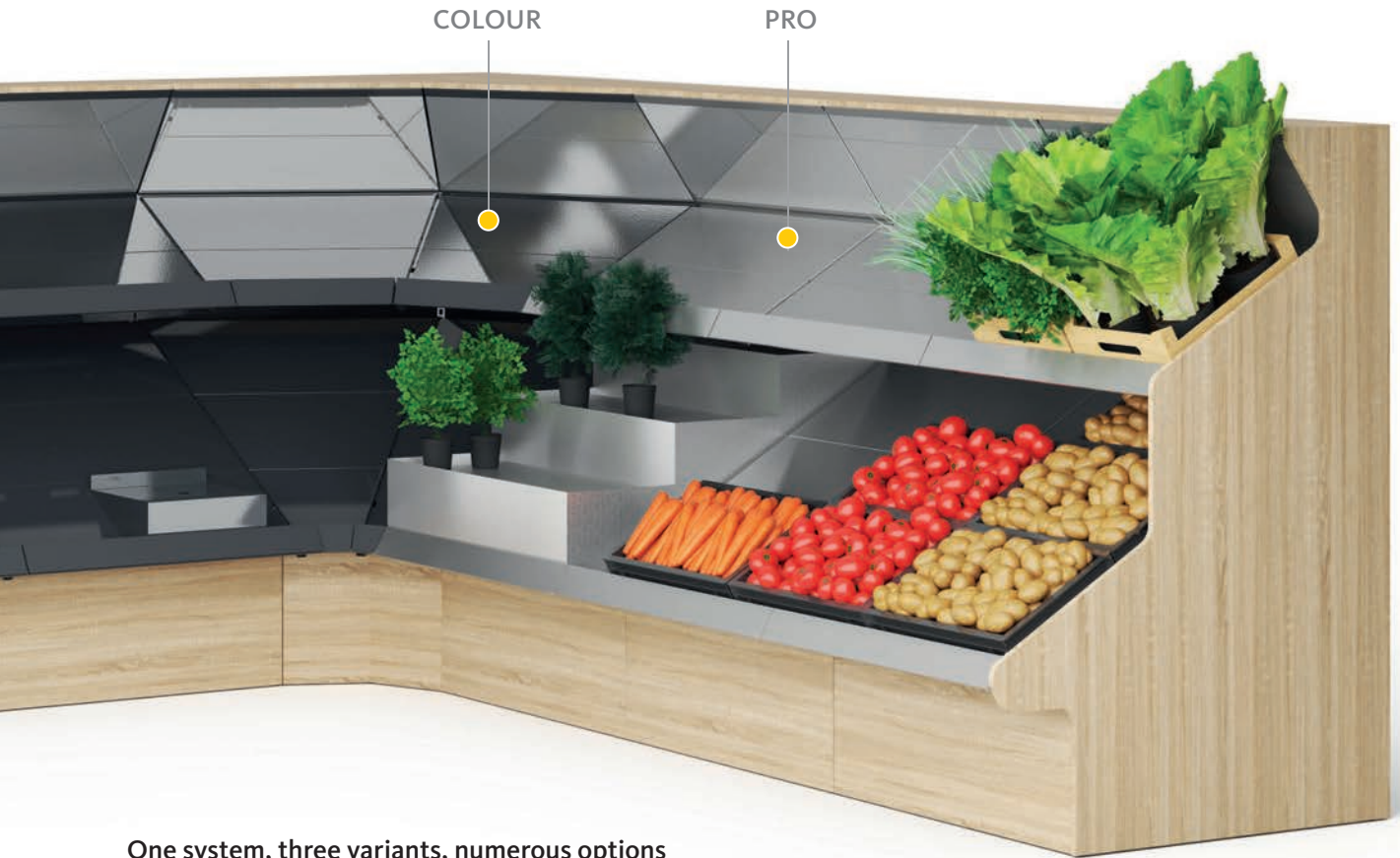

## One system, three variants, numerous options

A shelving system that can be easily adapted to growing business and changing demands: The first step is to put together a low-cost entry-level solution that can be enlarged by additional modules as needed, changed visually and upgraded to appeal to the needs of premium customers.

You can choose from three designs:

**BASIC:**  Open metal tubing system, e. g. for discounters

**PRO:**  Design in brushed stainless steel

**COLOUR:**  Powder-coated metal in RAL standard colours\*  
\*custom colours on request



# The difference is in the details

It's worth taking a close look: KIND4stores shelving systems incorporate the latest developments and decades of experience.

Adjustable to accommodate different product sizes and formats through **display depths** of 400, 600, 800 or 1200 mm.



**Bag dispensers** can be placed in various positions easily accessible for customers.

Stock corner units efficiently: **horizontal dividers for corner shelves** create order and a clear structure.

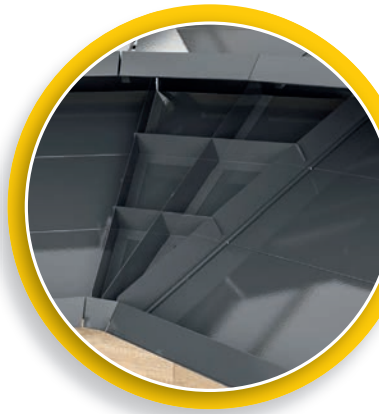

**Crate stoppers** secure product crates in place.



**Various finishes** offer individual design options.



**Drawers** at the front of the shelving unit provide additional.







The **herb ladder** can be placed anywhere to spice up the shelf structure.

**Stainless steel display surfaces** make cleaning easier, thus guaranteeing a high standard of hygiene.



The **display depths** are in line with standard crate sizes, allowing the gap-free filling of the shelves.

**100 mm price holders** ensure full visibility of price labelling. The cover protects against dirt.



**Front panel with sealing lip** magnetic, protects against damage and water penetration – also when using cleaning machines. (Only available for metal finishes!)

The scales can be placed on a **pedestal** at the front of the shelf, where they are easy and convenient for customers to use.





# GOOD(S) VARIETY – VERSATILE SHELF SOLUTIONS!

This brochure contains only a small selection of the **KIND4stores solutions** for fruit & vegetable displays.

We would be pleased to advise you personally (in an individual consultation) and give you an idea what your specific market could look like.

**Our experts look forward to discussing options with you!**



# INFORMATION

## Imprint

### **HARRES Metall-design GmbH**

Max-Eyth-Str. 10

59581 Warstein, Deutschland

CEO:

Nils Franke, Daniel Schwanitz

Telephone +49 902 9775-0

E-mail: [info-DE@KIND4stores.com](mailto:info-DE@KIND4stores.com)

Register court: AG Arnsberg

Commercial register: HRB 6615

VAT ID: 183384179

Tax No.: 33057171244

The illustrations shown in this catalogue are primarily for illustrative purposes; actual configurations, dimensions and colours may vary.

HARRES Metall-design GmbH is not liable for damage caused by the use of parts/products from other manufacturers in combination with our original system.

Subject to technical changes.

Our general terms and conditions of delivery and payment apply.

Copyright of the KIND4stores brand exists for all HK and fruit & vegetables core products.

# INFORMATION

## Ordering information | Colour key

### Ordering information

The shop fitting system for fruit and vegetables offers an extensive range of units in a wide variety of combination and design options, including product-specific additions.

To make it as easy as possible for you to select and put together your desired configuration, here are some notes on dimensions, abbreviations and colour keys:

- All dimensions indicated in this catalogue are nominal dimensions.
- All dimensions are indicated in millimetres  
**Example:** D570 = depth 570 mm, H2200 = height 2200 mm
- Please refer to the table on the right for abbreviations/short names

### Colour key

The **HK**system units are available in the following RAL standard colours. Simply add the four-digit colour code of our RAL colour key to the item numbers of the **HK**products in your order.

**Example:** HK25item in RAL 7016 (Anthracite grey)

Item number + colour code addition number  
= C100020-2377

Naturally, we are also happy to fulfil special colour requests and will be pleased to advise you.

### Abbreviations/short names:

L	Length
H	Height
T	Depth
AS	Axle size
F&V	Fruit & Vegetables

HK25 – RAL standard colours		Colour code addition number
RAL 7016	Anthracite-grey	-2377
RAL 7022	Umbra grey	-2306
RAL 7024	Graphite grey	-2303
RAL 9006	White aluminum	-2388
RAL 9010	Pure white	-2302

**OUR MULTI-  
FUNCTIONAL  
SHELVING  
SYSTEM FOR  
FRUIT AND  
VEGETABLES:**

# F&V SHELF OVERVIEW

## VERDE 1-tier | AS 1000/1250

with tray



Interior corner 45° | with tray



with crosspieces



with tray and mirror



Interior corner 45° | with tray and mirror



with crosspieces and mirror



### gondola

with tray | H1252/H1052



with crosspieces | H1252/H1052



## VEGANO 2-tier | AS 1000/1250

with tray



Interior corner 45° | with tray



with crosspieces



## VEGANO PLUS 2-tier | AS 1000/1250

with tray



Interior corner 45° | with tray



Exterior corner 45° | with tray



with tray and mirror



Interior corner 45° | with tray and mirror



## CASCADE 3-tier | AS 1000/1250

with tray



Interior corner 45° | with tray



with crosspieces



## QUADRO 3-tier/4-tier | AS 1000/1250

3-tier/4-tier | with deep shelf



4-tier



## GUSTO | with potato crate | AS 1250

2-tier | H1600



2-tier | H1800



## VERDE | 1-tier | with tray | AS 1000/1250

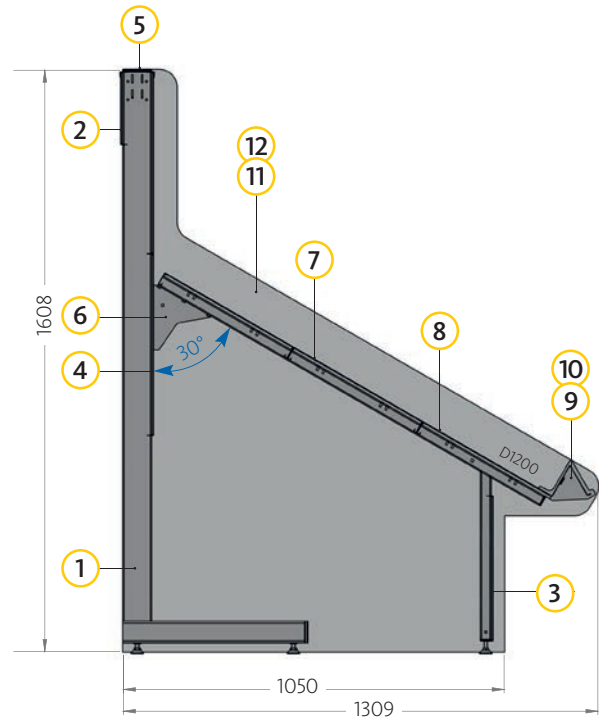

### LIST OF ITEMS

No.	Item description	Number		Item number	
		Basic unit	Extension unit	AS 1000	AS 1250
1	L-shaped upright H1600 D470 HK25	2	1	C100006-	C100006-
2	Back panel H200 HK25	1	1	C100020-	C100014-
3	Back panel H400 HK25	1	1	C001009-	C001006-
4	Back panel H500 HK25	2	2	C001008-	C001005-
5	Cover plate for 80x30 mm HK25	1	1	C100100-	C100101-
6	Tray frame with upright H440 D1200 30° F&V	2	1	C100144-	C100144-
7	Shelf D400 F&V	2	2	OG00027-	OG00028-
8	Shelf D400 with price rail H100 centre F&V	1	1	OG00033-	OG00034-
9	Price rail cover H100 right F&V	1	-	OG00017-	OG00017-
10	Price rail cover H100 left F&V	1	-	OG00018-	OG00018-
11	End panel left F&V	1	-	C209587-	C209587-
12	End panel right F&V	1	-	C209586-	C209586-

### STANDARD COLOURS

Colour code addition number:



**RAL 7016**  
Anthracite grey  
- 2377



**RAL 7022**  
Umbra grey  
- 2306



**RAL 7024**  
Graphite grey  
- 2303



**RAL 9006**  
White aluminum  
- 2388



**RAL 9010**  
Pure white  
- 2302



## VERDE | interior corner (IC) 45° | 1-tier | with tray

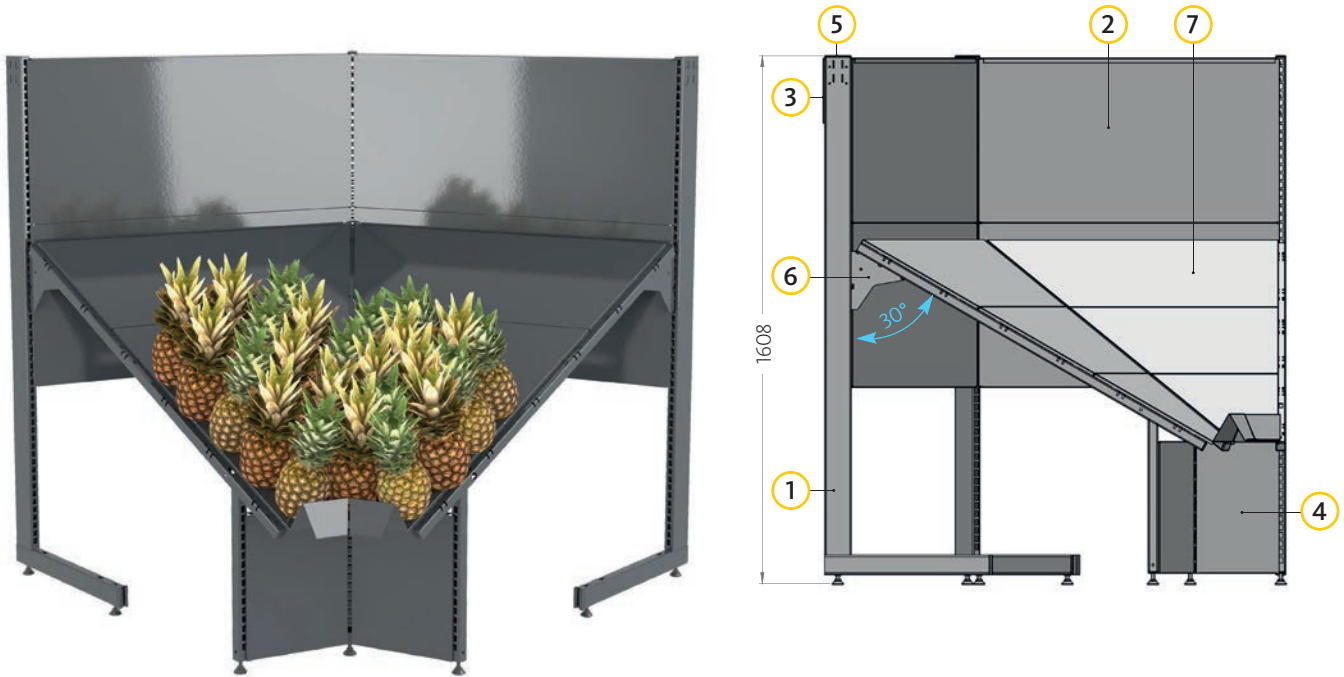

### LIST OF ITEMS

No.	Item description	Number	Item number
			<b>IC45° D1200</b>
1	L-shaped upright H1600 D470 HK25	3	C100006-
2	Back panel H500 L990 HK25	4	C001008-
3	Back panel flat IC45° H200 L1051 HK25	2	C100107-
4	Back panel flat (front) IC45° D1200 H400 L273 30° HK25	2	C110121-
5	Cover plate for 80x30 mm IC45° HK25	2	C100102-
6	Tray frame with upright H440 D1200 30° F&V	3	C100144-
7	Shelf IC45° with price rail D1200 30° F&V	2	OG00116-set

### STANDARD COLOURS

Colour code addition number:

 <b>RAL 7016</b> Anthracite grey - 2377	 <b>RAL 7022</b> Umbra grey - 2306	 <b>RAL 7024</b> Graphite grey - 2303	 <b>RAL 9006</b> White aluminum - 2388	 <b>RAL 9010</b> Pure white - 2302
--	---	--	---	---

Any other colours upon request!

## VERDE | 1-tier | with tray and mirror | AS 1000/1250

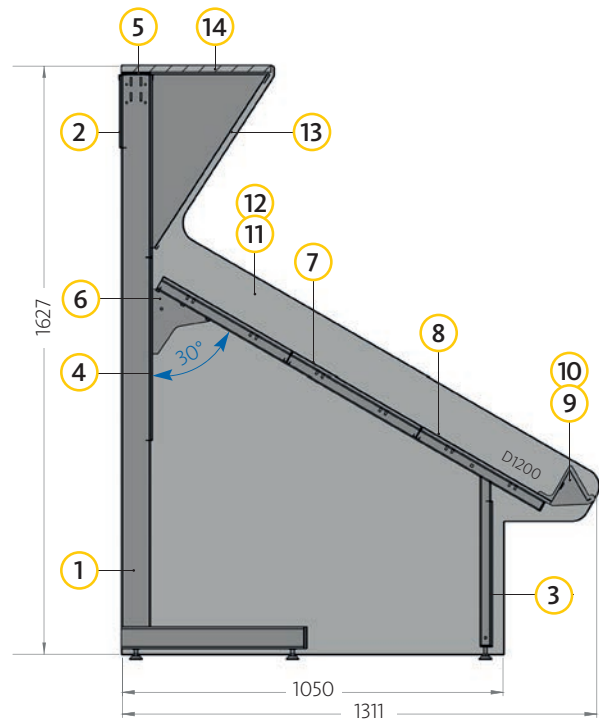

### LIST OF ITEMS

No.	Item description	Number		Item number	
		Basic unit	Extension unit	AS 1000	AS 1250
1	L-shaped upright H1600 D470 HK25	2	1	C100006-	C100006-
2	Back panel H200 HK25	1	1	C100020-	C100014-
3	Back panel H400 HK25	1	1	C001009-	C001006-
4	Back panel H500 HK25	2	2	C001008-	C001005-
5	Cover plate for 80x30 mm HK25	1	1	C100100-	C100101-
6	Tray frame with upright H440 D1200 30° F&V	2	1	C100144-	C100144-
7	Shelf D400 F&V	2	2	OG00027-	OG00028-
8	Shelf D400 with price rail H100 centre F&V	1	1	OG00033-	OG00034-
9	Price rail cover H100 right F&V	1	-	OG00017-	OG00017-
10	Price rail cover H100 left F&V	1	-	OG00018-	OG00018-
11	End panel left F&V	1	-	C209770L-	C209770L-
12	End panel right F&V	1	-	C209770R-	C209770R-
13	Mirror holder F&V	1	1	C100274-	C100275-
14	Wooden cover mirror end F&V	2	-	C209774-	C208924-
15	Wooden cover mirror centre F&V	-	1	C209773-	C208923-

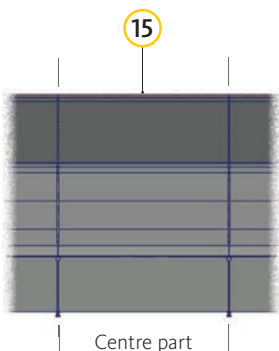

**Please note:** please order 1 unit less of item 15 since the "basic unit" of item 14 includes 2 items.

### STANDARD COLOURS

Colour code addition number:

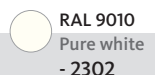
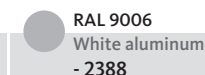
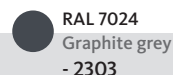
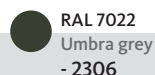
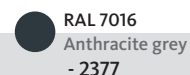

## VERDE | interior corner (IC) 45° | 1-tier | with tray and mirror

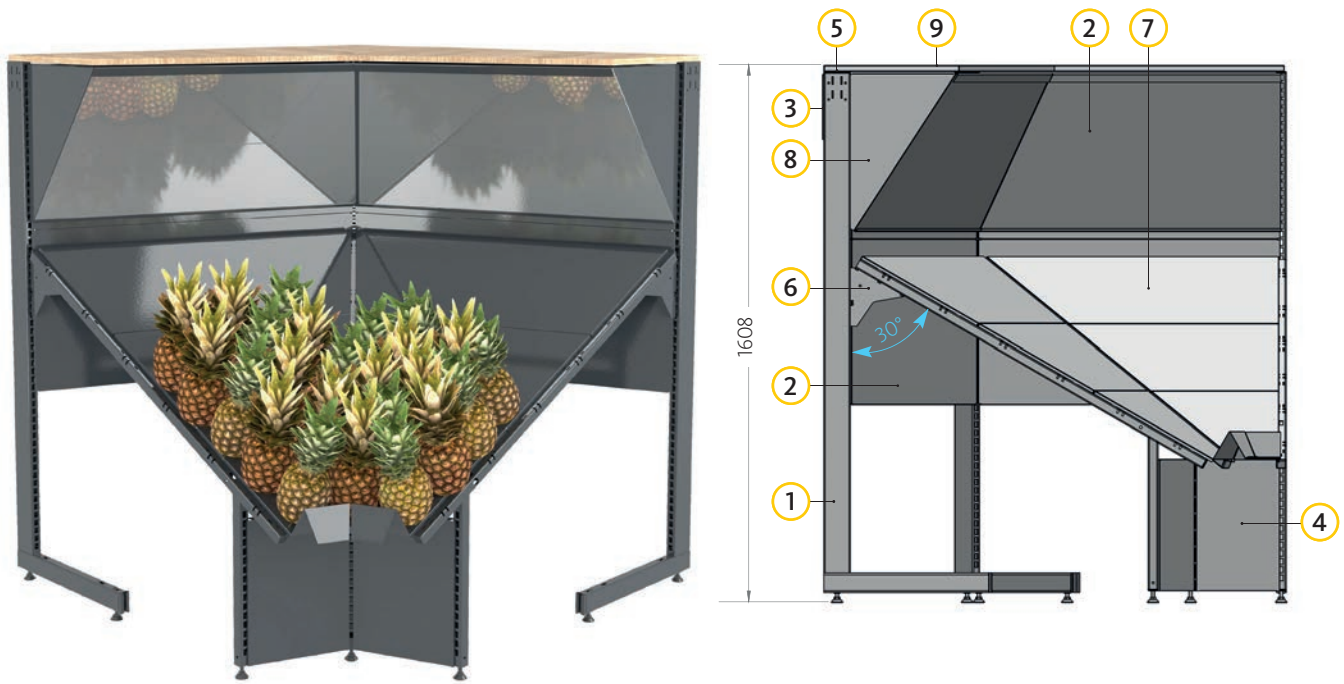

### LIST OF ITEMS

No.	Item description	Number	Item number
			<b>IC45° D1200</b>
1	L-shaped upright H1600 D470 HK25	3	C100006-
2	Back panel H500 L990 HK25	4	C001008-
3	Back panel flat IC45° H200 L1051 HK25	2	C100107-
4	Back panel flat (front) IC45° H400 L273 30° HK25	2	C110121-
5	Cover plate for 80x30 mm IC45° HK25	2	C100102-
6	Tray frame with upright H440 D1200 30° F&V	3	C100144-
7	Shelf IC45° with price rail D1200 30° F&V	2	OG00116-set
8	Mirror holder IC45° F&V	2	C100872-
9	Wooden cover mirror IC 2x45° F&V	2	C211247-

### STANDARD COLOURS

Colour code addition number:



**RAL 7016**  
Anthracite grey  
- 2377



**RAL 7022**  
Umbra grey  
- 2306



**RAL 7024**  
Graphite grey  
- 2303



**RAL 9006**  
White aluminum  
- 2388



**RAL 9010**  
Pure white  
- 2302

Any other colours upon request!

## VERDE | 1-tier | with crosspieces | AS 1000/1250

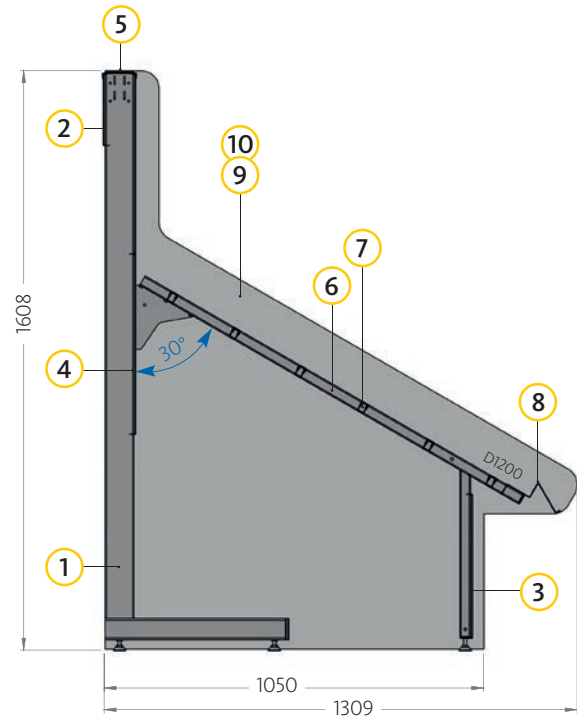

### LIST OF ITEMS

No.	Item description	Number		Item number	
		Basic unit	Extension unit	AS 1000	AS 1250
1	L-shaped upright H1600 D470 HK25	2	1	C100006-	C100006-
2	Back panel H200 HK25	1	1	C100020-	C100014-
3	Back panel H400 HK25	1	1	C001009-	C001006-
4	Back panel H500 HK25	2	2	C001008-	C001005-
5	Cover plate for 80x30 mm HK25	1	1	C100100-	C100101-
6	Tray frame with upright H440 D1200 30° F&V	2	1	C100144-	C100144-
7	Crosspiece F&V	6	6	OG00021-	OG00022-
8	Holder for price rail H100 F&V	1	1	OG00096-	OG00097-
9	End panel left F&V	1	-	C209587-	C209587-
10	End panel right F&V	1	-	C209586-	C209586-

### STANDARD COLOURS

Colour code addition number:

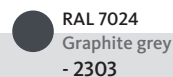
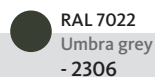
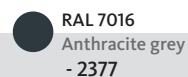

## VERDE | 1-tier | with crosspieces and mirror | AS 1000/1250

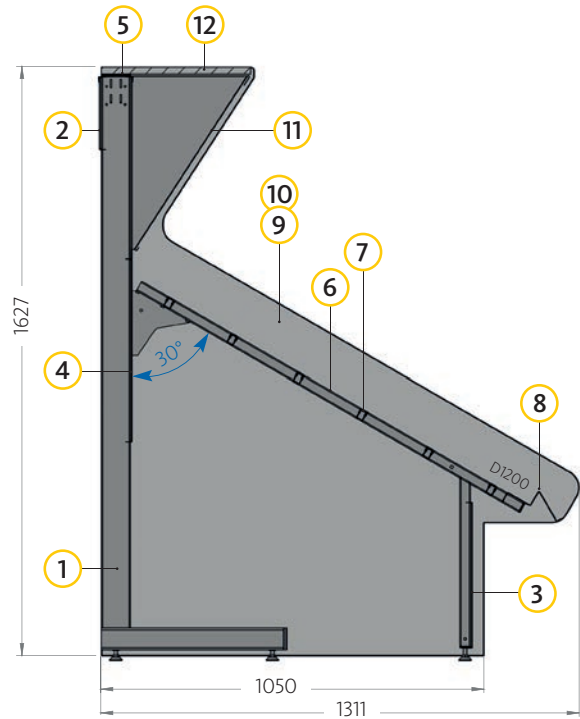

### LIST OF ITEMS

No.	Item description	Number		Item number	
		Basic unit	Extension unit	AS 1000	AS 1250
1	L-shaped upright H1600 D470 HK25	2	1	C100006-	C100006-
2	Back panel H200 HK25	1	1	C100020-	C100014-
3	Back panel H400 HK25	1	1	C001009-	C001006-
4	Back panel H500 HK25	2	2	C001008-	C001005-
5	Cover plate for 80x30 mm HK25	1	1	C100100-	C100101-
6	Tray frame with upright H440 D1200 30° F&V	2	1	C100144-	C100144-
7	Crosspiece F&V	6	6	OG00021-	OG00022-
8	Holder for price rail H100 F&V	1	1	OG00096-	OG00097-
9	End panel left F&V	1	-	C209770L	C209770L
10	End panel right F&V	1	-	C209770R	C209770R
11	Mirror holder F&V	1	1	C100274-	C100275-
12	Wooden cover mirror end F&V	2	-	C209774-	C208924-
13	Wooden cover mirror centre F&V	-	1	C209773-	C208923-

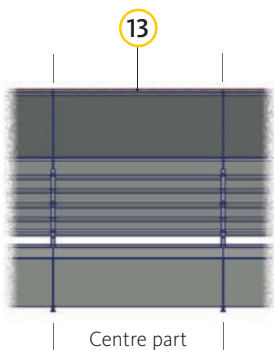

**Please note:** please order 1 unit less of item 13 since the "basic unit" of item 12 includes 2 items.

### STANDARD COLOURS

Colour code addition number:

 RAL 7016 Anthracite grey - 2377	 RAL 7022 Umbra grey - 2306	 RAL 7024 Graphite grey - 2303	 RAL 9006 White aluminum - 2388	 RAL 9010 Pure white - 2302
---	--	---	--	--

Any other colours upon request!

## VERDE | 1-tier centre space | with tray | AS 1000/1250 | H1252

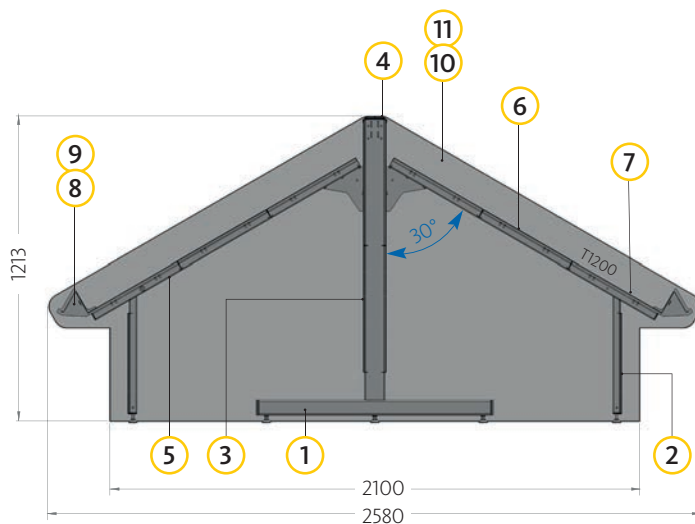

### LIST OF ITEMS

No.	Item description	Number		Item number	
		Basic unit	Extension unit	AS 1000	AS 1250
1	T-shaped upright H1200 D470 HK25	2	1	C100009-	C100009-
2	Back panel H400 HK25	2	2	C001009-	C001006-
3	Back panel H500 HK25	4	4	C001008-	C001005-
4	Cover plate for 80x30 mm HK25	1	1	C100100-	C100101-
5	Tray frame with upright H440 D1200 30° F&V	4	2	C100144-	C100144-
6	Shelf D400 F&V	4	4	OG00027-	OG00028-
7	Shelf D400 with price rail H100 centre F&V	2	2	OG00033-	OG00034-
8	Price rail cover H100 right F&V	2	-	OG00017-	OG00017-
9	Price rail cover H100 left F&V	2	-	OG00018-	OG00018-
10	End panel left F&V	2	-	SH03413L-	SH03413L-
11	End panel right F&V	2	-	SH03413R-	SH03413R-

### STANDARD COLOURS

Colour code addition number:

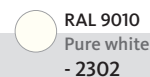
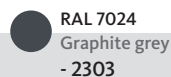
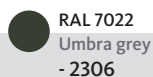
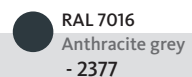

Any other colours upon request!

## VERDE | 1-tier centre space | with crosspieces | AS 1000/1250 | H1252

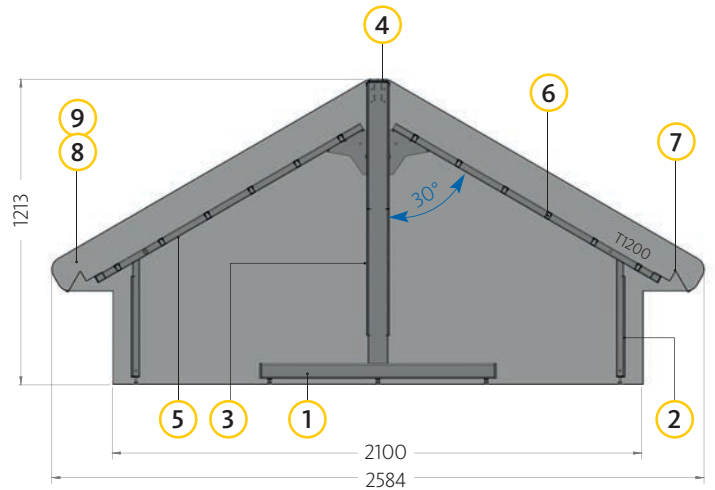

### LIST OF ITEMS

No.	Item description	Number		Item number	
				AS 1000	AS 1250
1	T-shaped upright H1200 D470 HK25	2	1	C100009-	C100009-
2	Back panel H400 HK25	2	2	C001009-	C001006-
3	Back panel H500 HK25	4	4	C001008-	C001005-
4	Cover plate for 80x30 mm HK25	1	1	C100100-	C100101-
5	Tray frame with upright H440 D1200 30° F&V	4	2	C100144-	C100144-
6	Crosspiece F&V	12	12	OG00021-	OG00022-
7	Holder for price rail H100 F&V	2	2	OG00096-	OG00097-
8	End panel left F&V	2	-	SH03413L-	SH03413L-
9	End panel right F&V	2	-	SH03413R-	SH03413R-

### STANDARD COLOURS

Colour code addition number:

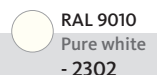
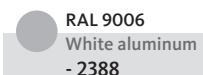
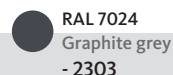
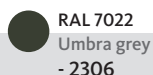
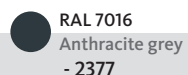

Any other colours upon request!

## VERDE | 1-tier centre space | with tray | AS1000/1250 | H1052

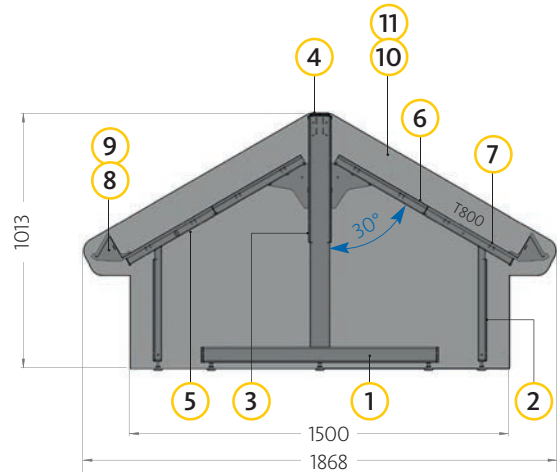

### LIST OF ITEMS

No.	Item description	Number		Item number	
		Basic unit	Extension unit	AS 1000	AS 1250
1	T-shaped upright H1000 D470 HK25	2	1	C100270-	C100270-
2	Back panel H400 HK25	2	2	C001009-	C001006-
3	Back panel H500 HK25	2	2	C001008-	C001005-
4	Cover plate for 80x30 mm HK25	1	1	C100100-	C100101-
5	Tray frame with upright H410 D800 30° F&V	4	2	C100269-	C100269-
6	Shelf D400 F&V	2	2	OG00027-	OG00028-
7	Shelf D400 with price rail H100 centre F&V	2	2	OG00033-	OG00034-
8	Price rail cover H100 right F&V	2	-	OG00017-	OG00017-
9	Price rail cover H100 left F&V	2	-	OG00018-	OG00018-
10	End panel left F&V	2	-	C209755L-	C209755L-
11	End panel right F&V	2	-	C209755R-	C209755R-

### STANDARD COLOURS

Colour code addition number:

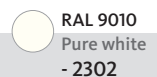
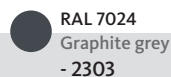
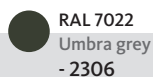
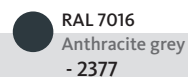



## VERDE | 1-tier centre space | with crosspieces | AS 1000/1250 | H1052

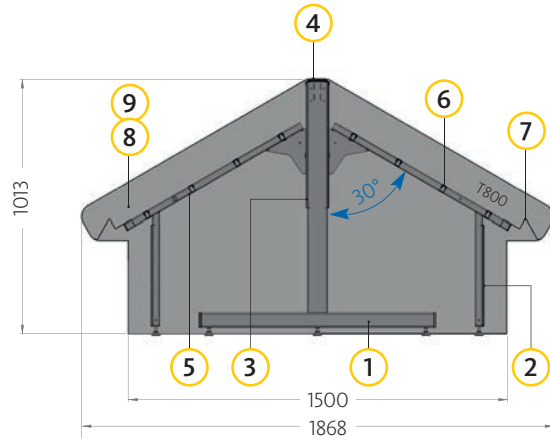

### LIST OF ITEMS

No.	Item description	Number		Item number	
		Basic unit	Extension unit	AS 1000	AS 1250
1	T-shaped upright H1000 D470 HK25	2	1	C100270-	C100270-
2	Back panel H400 HK25	2	2	C001009-	C001006-
3	Back panel H500 HK25	2	2	C001008-	C001005-
4	Cover plate for 80x30 mm HK25	1	1	C100100-	C100101-
5	Tray frame with upright H410 D800 30° F&V	4	2	C100269-	C100269-
6	Crosspiece F&V	8	8	OG00021-	OG00022-
7	Holder for price rail H100 F&V	2	2	OG00096-	OG00097-
8	End panel left F&V	2	-	C209755L-	C209755L-
9	End panel right F&V	2	-	C209755R-	C209755R-

### STANDARD COLOURS

Colour code addition number:

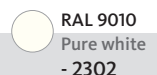
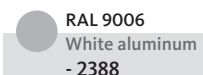
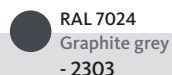
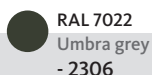
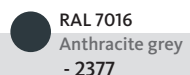

Any other colours upon request!

## VEGANO | 2-tier | with tray | AS 1000/1250

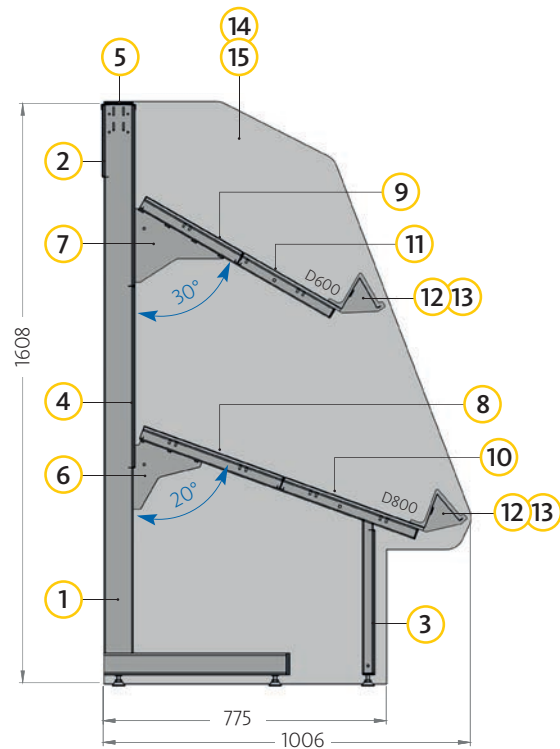

### LIST OF ITEMS

No.	Item description	Number		Item number	
		Basic unit	Extension unit	AS 1000	AS 1250
1	L-shaped upright H1600 D470 HK25	2	1	C100006-	C100006-
2	Back panel H200 HK25	1	1	C100020-	C100014-
3	Back panel H400 HK25	1	1	C001009-	C001006-
4	Back panel H500 HK25	2	2	C001008-	C001005-
5	Cover plate for 80x30 mm HK25	1	1	C100100-	C100101-
6	Tray frame with upright H440 D800 20° F&V	2	1	C100139-	C100139-
7	Tray frame D600 30° F&V	2	1	OG00005-	OG00005-
8	Shelf D400 F&V	1	1	OG00027-	OG00028-
9	Shelf D300 F&V	1	1	OG00024-	OG00025-
10	Shelf D400 with price rail H100 F&V	-	1	OG00033-	OG00034-
11	Shelf D300 with price rail H100 F&V	-	1	OG00030-	OG00031-
12	Price rail cover H100 right F&V	1	-	OG00017-	OG00017-
13	Price rail cover H100 left F&V	1	-	OG00018-	OG00018-
14	End panel left F&V	1	-	C209580-	C209580-
15	End panel right F&V	1	-	C209579-	C209579-

### STANDARD COLOURS

Colour code addition number:



**RAL 7016**  
Anthracite grey  
- 2377



**RAL 7022**  
Umbra grey  
- 2306



**RAL 7024**  
Graphite grey  
- 2303



**RAL 9006**  
White aluminum  
- 2388



**RAL 9010**  
Pure white  
- 2302

## VEGANO | interior corner (IC) 45° | 2-tier | with tray

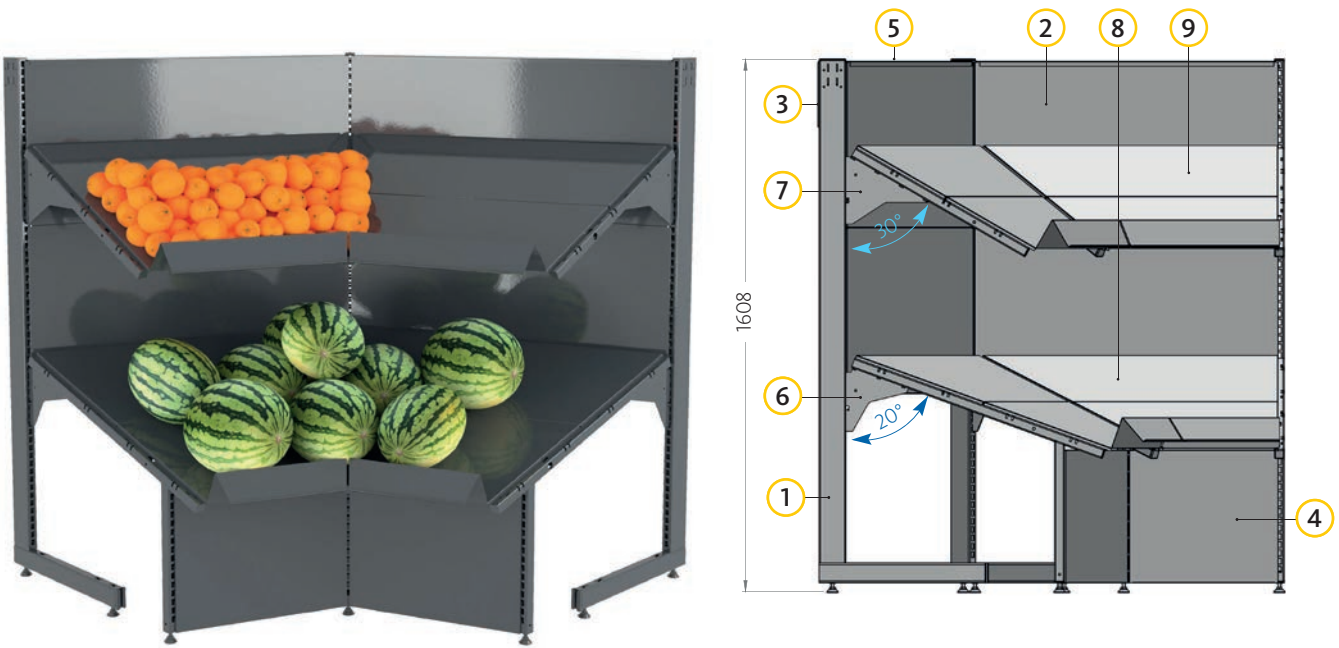

### LIST OF ITEMS

No.	Item description	Number	Item number
			<b>IC45° D800</b>
1	L-shaped upright H1600 D470 HK25	3	C100006-
2	Back panel H500 L990 HK25	4	C001008-
3	Back panel flat IC45° H200 L1051 HK25	2	C100107-
4	Back panel flat (front) IC45° D800 H400 L484 20° HK25	2	C100874-
5	Cover plate for 80x30 IC45° HK25	2	C100102-
6	Tray frame with upright H440 D800 20° F&V	3	C100139-
7	Tray frame D600 30° F&V	3	OG00005-
8	Shelf IC45° with price rail D800 20° F&V	2	OG00199-set
9	Shelf IC45° with price rail D600 30° F&V	2	OG00118-set

### STANDARD COLOURS

Colour code addition number:

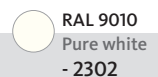
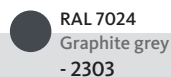
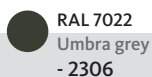
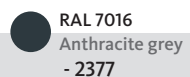

Any other colours upon request!

## VEGANO | 2-tier | with crosspieces | AS 1000/1250

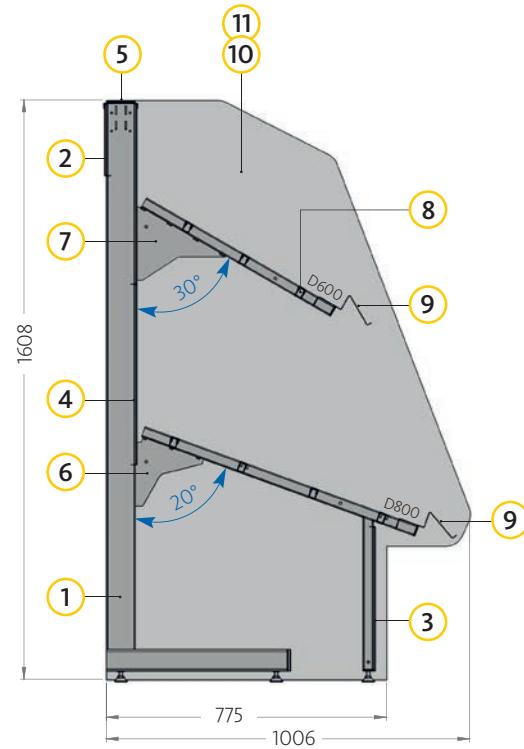

### LIST OF ITEMS

No.	Item description	Number		Item number	
		Basic unit	Extension unit	AS 1000	AS 1250
1	L-shaped upright H1600 D470 HK25	2	1	C100006-	C100006-
2	Back panel H200 HK25	1	1	C100020-	C100014-
3	Back panel H400 HK25	1	1	C001009-	C001006-
4	Back panel H500 HK25	2	2	C001008-	C001005-
5	Cover plate for 80x30 mm HK25	1	1	C100100-	C100101-
6	Tray frame with upright H440 D800 20° F&V	2	1	C100139-	C100139-
7	Tray frame D600 30° F&V	2	1	OG00005-	OG00005-
8	Crosspiece F&V	7	7	OG00021-	OG00022-
9	Holder for price rail H100 F&V	2	2	OG00096-	OG00097-
10	End panel left F&V	1	-	C209580-	C209580-
11	End panel right F&V	1	-	C209579-	C209579-

### STANDARD COLOURS

Colour code addition number:

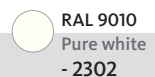
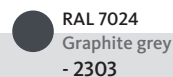
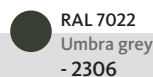
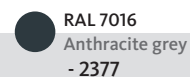

## VEGANO PLUS | 2-tier | with tray | AS 1000/1250

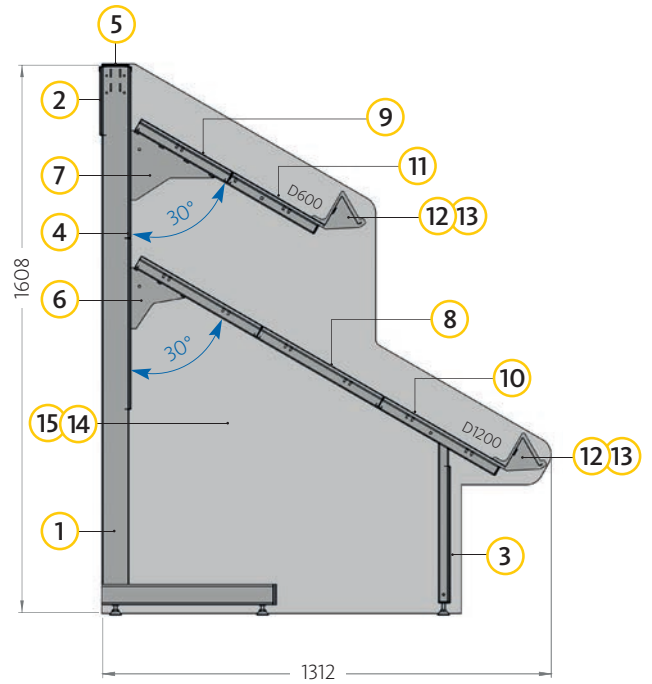





### LIST OF ITEMS

No.	Item description	Number		Item number	
		Basic unit	Extension unit	AS 1000	AS 1250
1	L-shaped upright H1600 D470 HK25	2	1	C100006-	C100006-
2	Back panel H200 HK25	1	1	C100020-	C100014-
3	Back panel H400 HK25	1	1	C001009-	C001006-
4	Back panel H500 HK25	2	2	C001008-	C001005-
5	Cover plate for 80x30 mm HK25	1	1	C100100-	C100101-
6	Tray frame with upright H440 D1200 30° F&V	2	1	C100144-	C100144-
7	Tray frame D600 30° F&V	2	1	OG00005-	OG00005-
8	Shelf D400 F&V	2	2	OG00027-	OG00028-
9	Shelf D300 F&V	1	1	OG00024-	OG00025-
10	Shelf with price rail D400 F&V	1	1	OG00033-	OG00034-
11	Shelf with price rail D300 F&V	1	1	OG00030-	OG00031-
12	Price rail cover H100 right F&V	2	-	OG00017-	OG00017-
13	Price rail cover H100 left F&V	2	-	OG00018-	OG00018-
14	End panel 2-tier left F&V	1	-	C208891-	C208891-
15	End panel 2-tier right F&V	1	-	C208893-	C208893-

### STANDARD COLOURS

Colour code addition number:

 RAL 7016 Anthracite grey - 2377	 RAL 7022 Umbra grey - 2306	 RAL 7024 Graphite grey - 2303	 RAL 9006 White aluminum - 2388	 RAL 9010 Pure white - 2302
---	--	---	--	--

Any other colours upon request!

## VEGANO PLUS | interior corner (IE) 45° | 2-tier | with tray

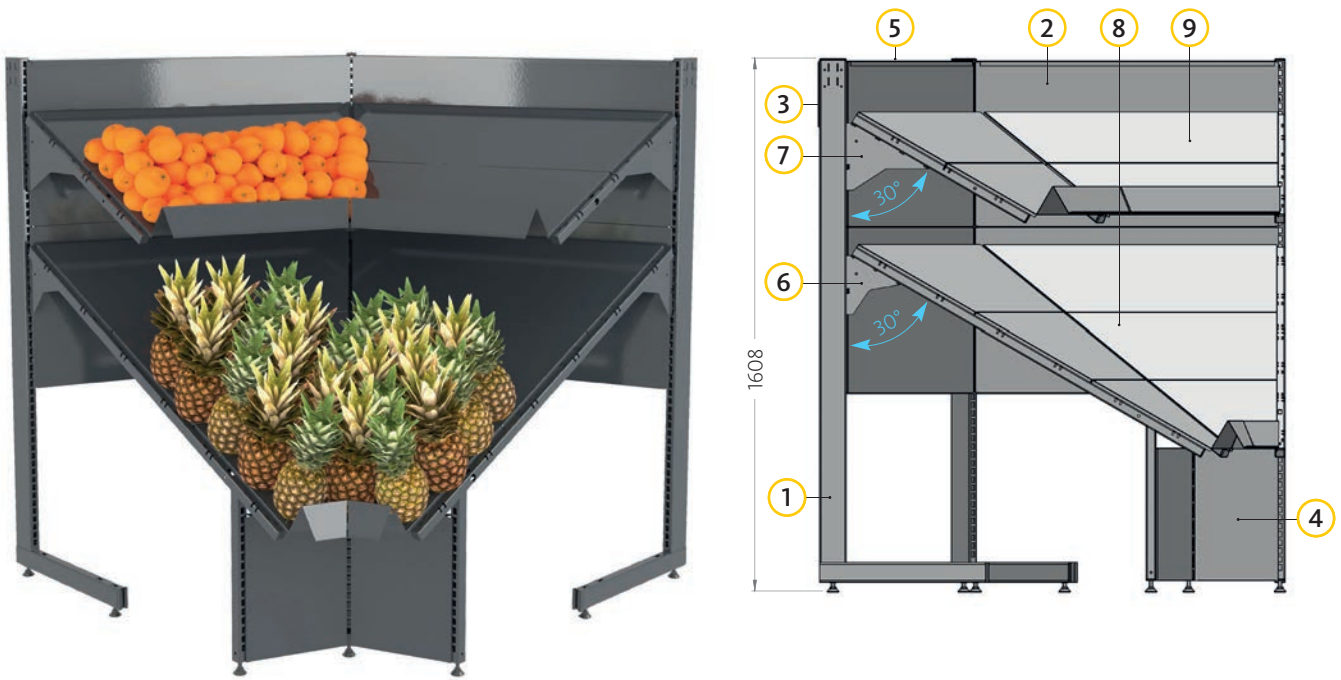

### LIST OF ITEMS

No.	Item description	Number	Item number
			<b>IC45° D1200</b>
1	L-shaped upright H1600 D470 HK25	3	C100006-
2	Back panel H500 L990 HK25	4	C001008-
3	Back panel flat IC45° H200 L1051 HK25	2	C100107-
4	Back panel flat (front) IC45° H400 L273 30° HK25	2	C110121-
5	Cover plate for 80x30 mm IC45° HK25	2	C100102-
6	Tray frame with upright H440 D1200 30° F&V	3	C100144-
7	Tray frame D600 30° F&V	3	OG00005-
8	Shelf IC45° with price rail D1200 30° F&V	2	OG00116-set
9	Shelf IC45° with price rail D600 30° F&V	2	OG00118-set

### STANDARD COLOURS

Colour code addition number:



**RAL 7016**  
Anthracite grey  
- 2377



**RAL 7022**  
Umbra grey  
- 2306



**RAL 7024**  
Graphite grey  
- 2303



**RAL 9006**  
White aluminum  
- 2388



**RAL 9010**  
Pure white  
- 2302

## VEGANO PLUS | exterior corner (EC) 45° | 2-tier | with tray

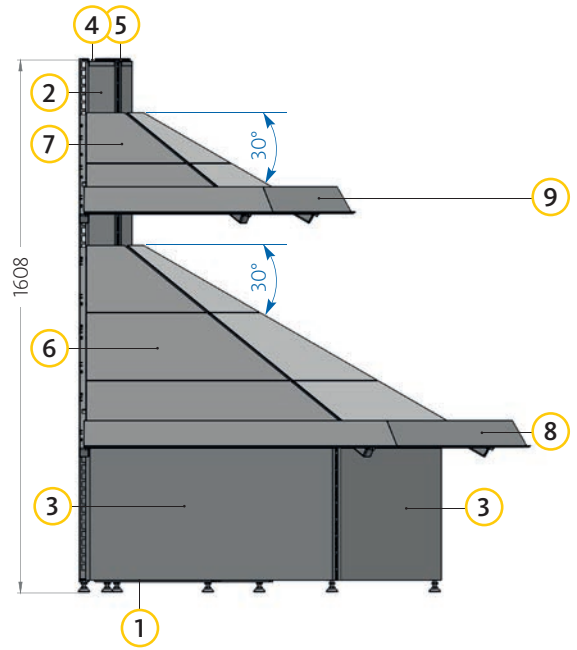

### LIST OF ITEMS

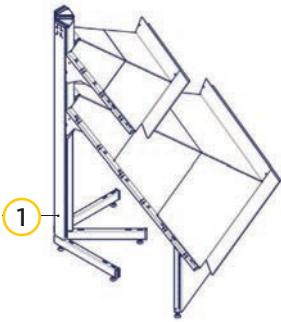

No.	Item description	Number	Item number
			<b>EC45° D1200</b>
1	L-shaped upright H1600 D470 HK25	3	C100006-
2	Back panel flat EC45° H800 L97 HK25	2	C001546-
3	Back panel flat EC45° H400 L800 F&V	2	C100599-
4	Cover plate for 80x30 mm EC45° HK25	2	C001547-
5	Magnetic holder for cover plate	4	4140000114
6	Tray frame with upright H440 D1200 30° F&V	3	C100144-
7	Tray frame D600 30° F&V	3	OG00005-
8	Shelf EC45° with price rail D1200 30° F&V	2	OG00158-set
9	Shelf EC45° with price rail D600 30° F&V	2	OG00160-set

### STANDARD COLOURS

Colour code addition number:

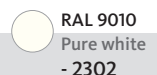
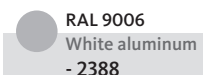
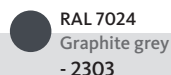
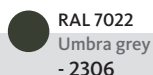
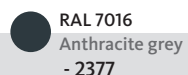

Any other colours upon request!

## VEGANO PLUS | 2-tier | with tray and mirror | AS 1000/1250

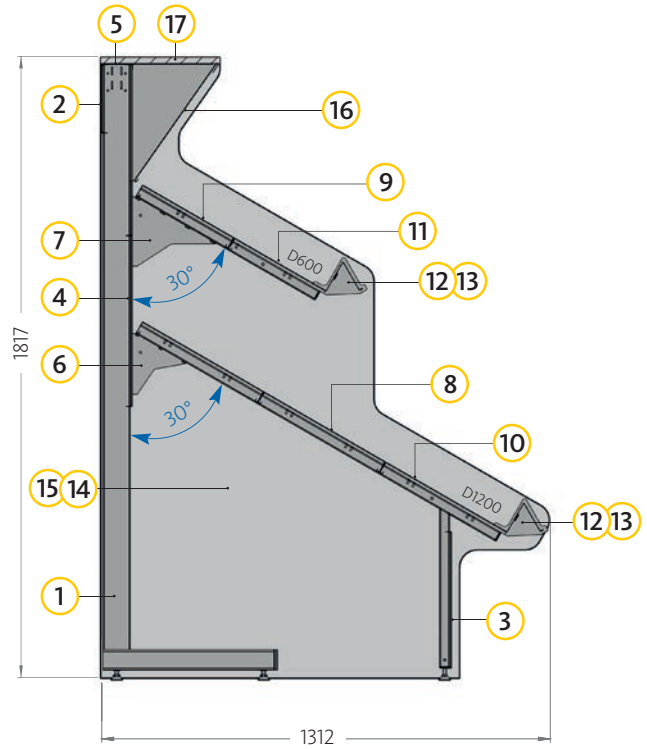

### LIST OF ITEMS

No.	Item description	Number		Item number	
		Basic unit	Extension unit	AS 1000	AS 1250
1	L-shaped upright H1800 D470 HK25	2	1	C100005-	C100005-
2	Back panel H200 HK25	1	1	C100020-	C100014-
3	Back panel H400 HK25	1	1	C001009-	C001006-
4	Back panel H500 HK25	2	2	C001008-	C001005-
5	Cover plate for 80x30 mm HK25	1	1	C100100-	C100101-
6	Tray frame with upright H440 D1200 30° F&V	2	1	C100144-	C100144-
7	Tray frame D600 30° F&V	2	1	OG00005-	OG00005-
8	Shelf D400 F&V	2	2	OG00027-	OG00028-
9	Shelf D300 F&V	1	1	OG00024-	OG00025-
10	Shelf with price rail D400 F&V	1	1	OG00033-	OG00034-
11	Shelf with price rail D300 F&V	1	1	OG00030-	OG00031-
12	Price rail cover H100 right F&V	2	-	OG00017-	OG00017-
13	Price rail cover H100 left F&V	2	-	OG00018-	OG00018-
14	End panel 2-tier with mirror F&V	1	-	C209630-	C209630-
15	End panel 2-tier right with mirror F&V	1	-	C209629-	C209629-
16	Mirror holder F&V	1	1	C100214-	C100208-
17	Wooden cover mirror end F&V	2	-	C209641-	C209626-
18	Wooden cover mirror centre F&V	-	1	C209642-	C209627-

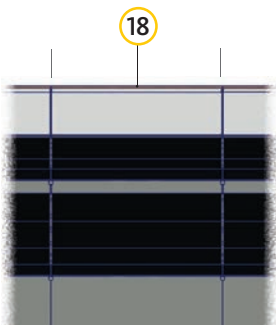





Centre part

**Please note:** please order 1 unit less of item 18 since the “basic unit” of item 17 already includes 2 units.

### STANDARD COLOURS

Colour code addition number:

 RAL 7016 Anthracite grey - 2377	 RAL 7022 Umbra grey - 2306	 RAL 7024 Graphite grey - 2303	 RAL 9006 White aluminum - 2388	 RAL 9010 Pure white - 2302
---	--	---	--	--

Any other colours upon request!



## VEGANO PLUS | interior corner (IC) 45° | 2-tier | with tray and mirror

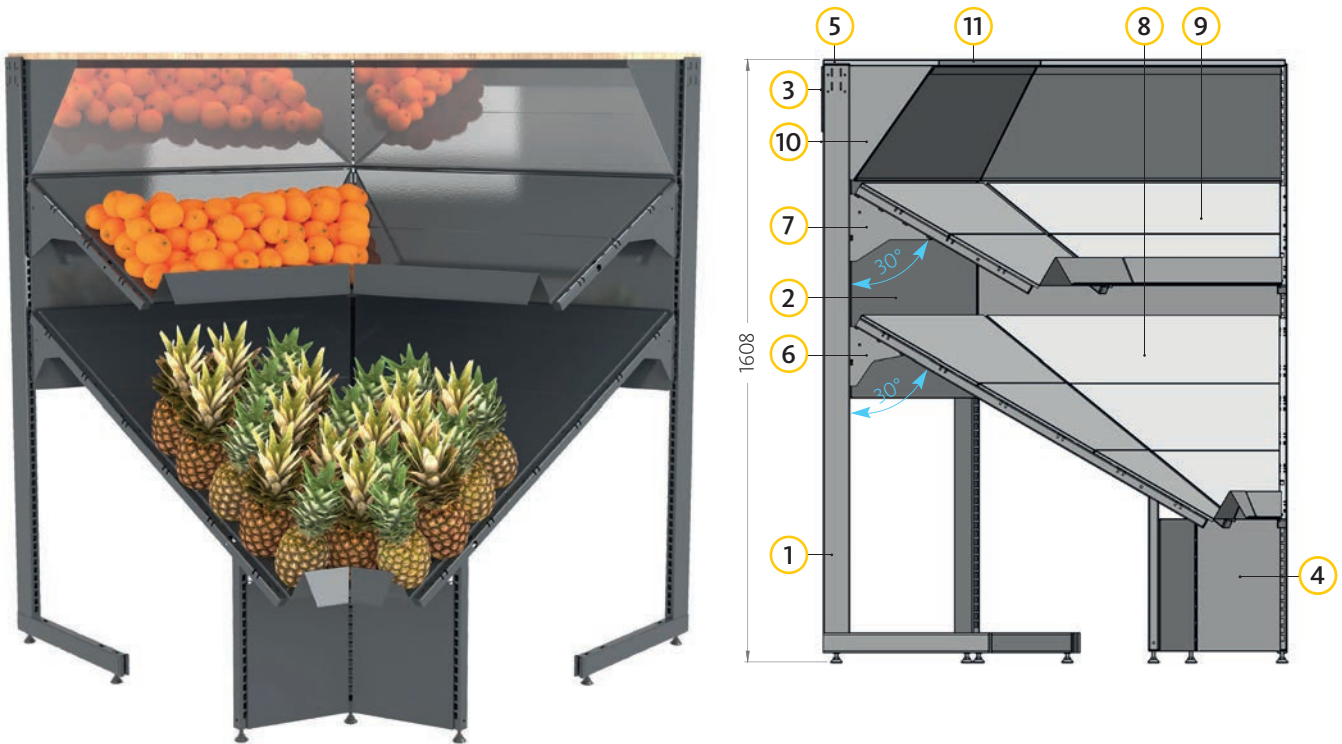

### LIST OF ITEMS

No.	Item description	Number	Item number
			<b>IC45° D1200</b>
1	L-shaped upright H1800 D470 HK25	3	C100005-
2	Back panel H500 L990 HK25	4	C001008-
3	Back panel flat IC45° H200 L1051 HK25	2	C100107-
4	Back panel flat (front) IC45° D1200 H400 L273 30° HK25	2	C110121-
5	Cover plate for 80x30 mm IC45° HK25	2	C100102-
6	Tray frame with upright H440 D1200 30° F&V	3	C100144-
7	Tray frame D600 30° F&V	3	OG00005-
8	Shelf IC45° with price rail D1200 30° F&V	2	OG00116-set
9	Shelf IC45° with price rail D600 30° F&V	2	OG00118-set
10	Mirror holder IC45°	2	C100241-
11	Wooden cover mirror IC 2x45° F&V	2	C209652-

### STANDARD COLOURS

Colour code addition number:

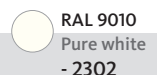
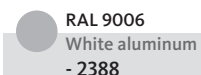
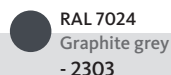
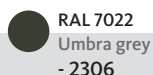
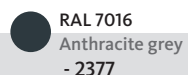

Any other colours upon request!

## CASCADE | 3-tier | with tray | AS 1000/1250

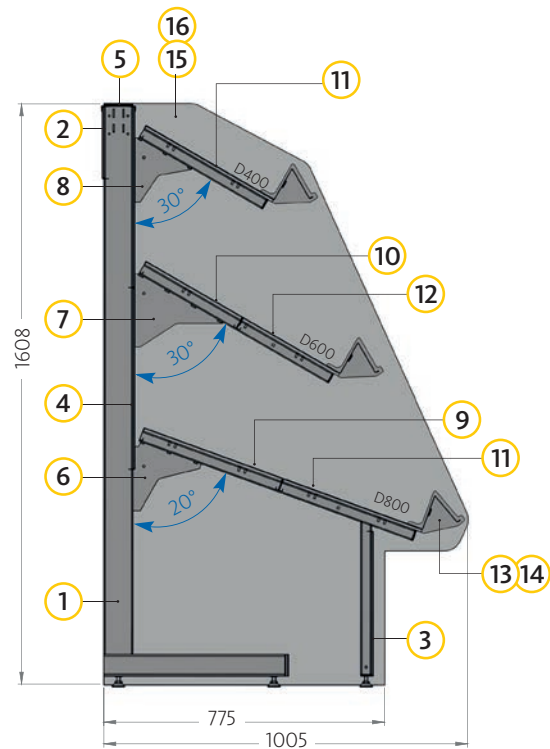

### LIST OF ITEMS

No.	Item description	Number		Item number	
		Basic unit	Extension unit	AS 1000	AS 1250
1	L-shaped upright H1600 D470 HK25	2	1	C100006-	C100006-
2	Back panel H200 HK25	1	1	C100020-	C100014-
3	Back panel H400 HK25	1	1	C001009-	C001006-
4	Back panel H500 HK25	2	2	C001008-	C001005-
5	Cover plate for 80x30 mm HK25	1	1	C100100-	C100101-
6	Shelf frame with upright H440 D800 20° F&V	2	1	C100139-	C100139-
7	Shelf frame D600 30° F&V	2	1	OG00005-	OG00005-
8	Shelf frame D400 30° F&V	2	1	OG00002-	OG00002-
9	Shelf D400 F&V	1	1	OG00027-	OG00028-
10	Shelf D300 F&V	1	1	OG00024-	OG00025-
11	Shelf with price rail D400 F&V	2	2	OG00033-	OG00034-
12	Shelf with price rail D300 F&V	1	1	OG00030-	OG00031-
13	Price rail cover H100 right F&V	3	-	OG00017-	OG00017-
14	Price rail cover H100 left F&V	3	-	OG00018-	OG00018-
15	End panel left F&V	1	-	C209580-	C209580-
16	End panel right F&V	1	-	C209579-	C209579-

17

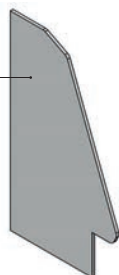





Accessories:

17	End panel both sides <b>H1800</b> for front panel	C211657-
----	---	----------

### STANDARD COLOURS

Colour code addition number:

 RAL 7016 Anthracite grey - 2377	 RAL 7022 Umbra grey - 2306	 RAL 7024 Graphite grey - 2303	 RAL 9006 White aluminum - 2388	 RAL 9010 Pure white - 2302
---	--	---	--	--

## CASCADE | interior corner (IC) 45° | 3-tier | with tray

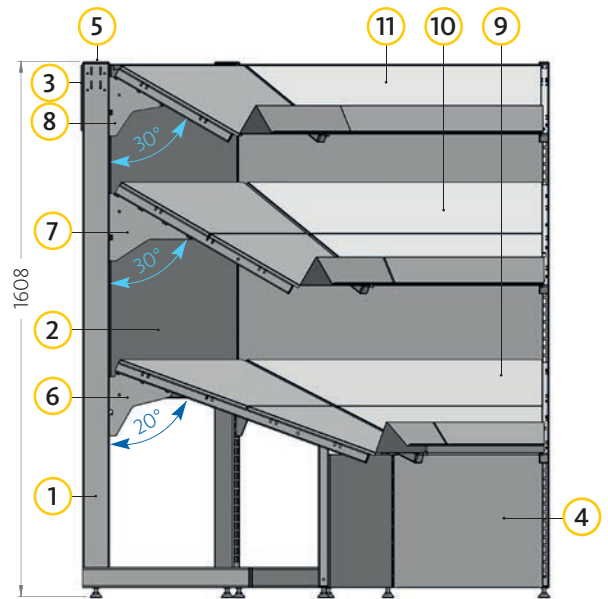

### LIST OF ITEMS

No.	Item description	Number	Item number
			<b>IC45° D800</b>
1	L-shaped upright H1600 D470 HK25	3	C100006-
2	Back panel H500 L990 HK25	4	C001008-
3	Back panel flat H200 L1051 IC45° HK25	2	C100107-
4	Back panel flat (front) IC45° D800 H400 L484 20° HK25	2	C100874-
5	Cover plate for 80x30 mm IC45° HK25	2	C100102-
6	Tray frame with upright H440 D800 20° F&V	3	C100139-
7	Tray frame D600 30° F&V	3	OG00005-
8	Tray frame D400 30° F&V	3	OG00002-
9	Shelf IC45° with price rail D800 20° F&V	2	OG00199-set
10	Shelf IC45° with price rail D600 30° F&V	2	OG00118-set
11	Shelf IC45° with price rail D400 30° F&V	2	OG00113-set

### STANDARD COLOURS

Colour code addition number:

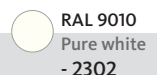
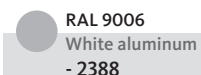
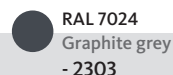
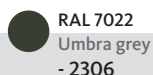
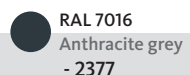

Any other colours upon request!

## CASCADE | 3-tier | with crosspieces | AS 1000/1250

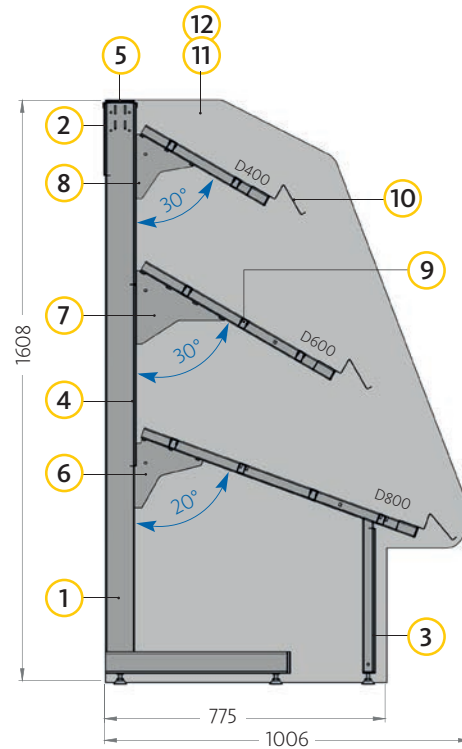

### LIST OF ITEMS

No.	Item description	Number		Item number	
		Basic unit	Extension unit	AS 1000	AS 1250
1	L-shaped upright H1600 D470 HK25	2	1	C100006-	C100006-
2	Back panel H200 HK25	1	1	C100020-	C100014-
3	Back panel H400 HK25	1	1	C001009-	C001006-
4	Back panel H500 HK25	2	2	C001008-	C001005-
5	Cover plate for 80x30 mm HK25	1	1	C100100-	C100101-
6	Tray frame with upright H440 D800 20° F&V	2	1	C100139-	C100139-
7	Tray frame D600 30° F&V	2	1	OG00005-	OG00005-
8	Tray frame D400 30° F&V	2	1	OG00002-	OG00002-
9	Crosspiece F&V	9	9	OG00021-	OG00022-
10	Holder for price rail H100 F&V	3	3	OG00096-	OG00097-
11	End panel left F&V	1	-	C209580-	C209580-
12	End panel right F&V	1	-	C209579-	C209579-

### STANDARD COLOURS



**RAL 7016**  
Anthracite grey  
- 2377



**RAL 7022**  
Umbra grey  
- 2306



**RAL 7024**  
Graphite grey  
- 2303



**RAL 9006**  
White aluminum  
- 2388



**RAL 9010**  
Pure white  
- 2302

Colour code addition number:

# F&V SHELF



## QUADRO | 3-tier to 4-tier | with deep shelf at the bottom | AS 1000/1250

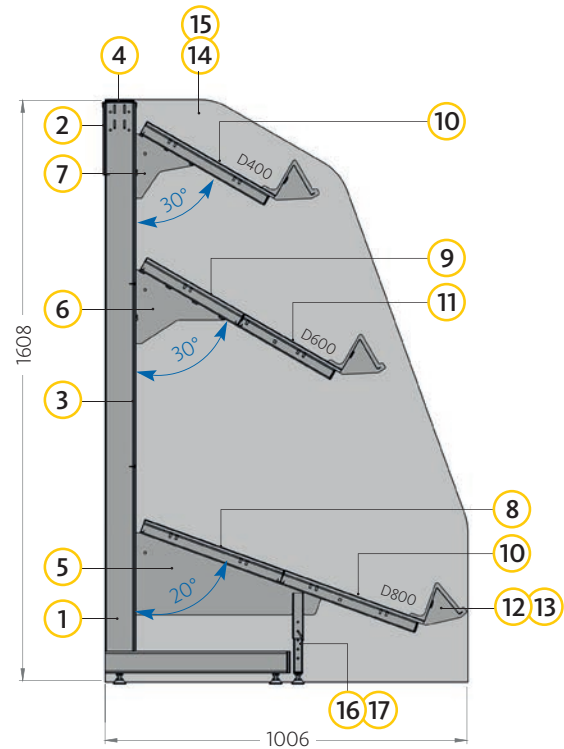

### LIST OF ITEMS

No.	Item description	Number		Item number	
		Basic unit	Extension unit	AS 1000	AS 1250
1	L-shaped upright H1600 D470 HK25	2	1	C100006-	C100006-
2	Back panel H200 HK25	1	1	C100020-	C100014-
3	Back panel H500 HK25	3	3	C001008-	C001005-
4	Cover plate for 80X30 mm HK25	1	1	C100100-	C100101-
5	Tray frame D800 20° F&V	1	1	C101026-	C101026-
6	Tray frame D600 30° F&V	1	1	OG00005-	OG00005-
7	Tray frame D400 30° F&V	1	1	OG00002-	OG00002-
8	Shelf D400 F&V	1	1	OG00027-	OG00028-
9	Shelf D300 F&V	1	1	OG00024-	OG00025-
10	Shelf with price rail D400 F&V	2	2	OG00033-	OG00034-
11	Shelf with price rail D300 F&V	1	1	OG00030-	OG00031-
12	Price rail cover H100 right F&V	3	-	OG00017-	OG00017-
13	Price rail cover H100 left F&V	3	-	OG00018-	OG00018-
14	End panel H1600 left F&V	1	-	C211489-	C211489-
15	End panel H1600 right F&V	1	-	C211488-	C211488-
16	Support tube HK25 (alternatively for SL)	2	1	C101028-	C101028-
17	Support tube with height-adjustable foot HK25 (alternatively for SL)	2	1	C101029-	C101029-

Adjustable support for SL

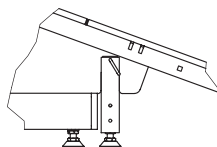
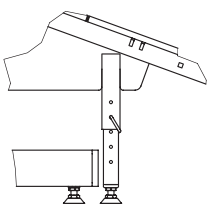

### STANDARD COLOURS

● RAL 7016  
Anthracite grey  
- 2377

● RAL 7022  
Umbra grey  
- 2306

● RAL 7024  
Graphite grey  
- 2303

● RAL 9006  
White aluminum  
- 2388

● RAL 9010  
Pure white  
- 2302

Colour code addition number:

# F&V SHELF

## QUADRO | 4-tier | AS 1000/1250

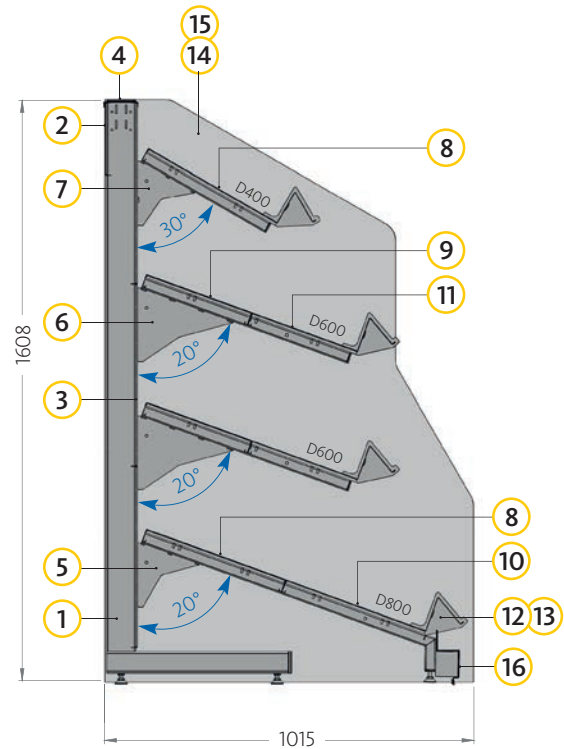

### LIST OF ITEMS

No.	Item description	Number		Item number	
		Basic unit	Extension unit	AS 1000	AS 1250
1	L-shaped upright H1600 D470 HK25	2	1	C100006-	C100006-
2	Back panel H200 HK25	1	1	C100020-	C100014-
3	Back panel H500 HK25	3	3	C001008-	C001005-
4	Cover plate for 80x30 mm HK25	1	1	C100100-	C100101-
5	Shelf frame with support H150 D800 F&V	1	1	OG00006-	OG00006-
6	Shelf frame D600 20° F&V	2	2	OG00003-	OG00003-
7	Shelf frame D400 30° F&V	1	1	OG00002-	OG00002-
8	Shelf D400 F&V	1	1	OG00027-	OG00028-
9	Shelf D300 F&V	2	2	OG00024-	OG00025-
10	Shelf with price rail D400 F&V	2	2	OG00033-	OG00034-
11	Shelf with price rail D300 F&V	2	2	OG00030-	OG00031-
12	Price rail cover H100 right F&V	4	-	OG00017-	OG00017-
13	Price rail cover H100 left F&V	4	-	OG00018-	OG00018-
14	End panel H1600 left F&V	1	-	C210026L-	C210026L-
15	End panel H1600 right F&V	1	-	C210026R-	C210026R-
16	Bumper base H75/H145 HK25	1	1	C001388-	C001387-

### STANDARD COLOURS

Colour code addition number:

 RAL 7016 Anthracite grey - 2377	 RAL 7022 Umbra grey - 2306	 RAL 7024 Graphite grey - 2303	 RAL 9006 White aluminum - 2388	 RAL 9010 Pure white - 2302
---	--	---	--	--

Any other colours upon request!

## GUSTO | 2-tier | with potato crate | AS 1250 | H1600

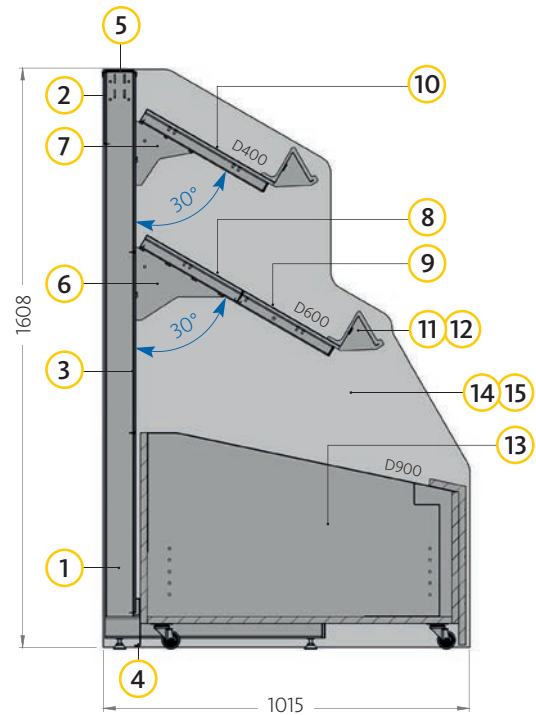

### LIST OF ITEMS

No.	Item description	Number		Item number
		Basic unit	Extension unit	
				<b>AS 1250</b>
1	L-shaped upright H1600 D570 HK25	2	1	C100082-
2	Back panel H200 HK25	1	1	C100014-
3	Back panel H500 HK25	3	3	C001005-
4	Pallet bumper HK25	1	1	C001099-
5	Cover plate for 80x30 mm HK25	1	1	C100101-
6	Tray frame D600 30° F&V	1	1	OG00005-
7	Tray frame D400 30° F&V	1	1	OG00002-
8	Shelf D300 F&V	1	1	OG00025-
9	Shelf D300 with price rail H100 F&V	1	1	OG00031-
10	Shelf D400 with price rail H100 F&V	1	1	OG00034-
11	Price rail cover H100 right F&V	2	-	OG00017-
12	Price rail cover H100 left F&V	2	-	OG00018-
13	Potato crate L1250 H600 D900 F&V	1	1	C208930-
14	End panel left 2-tier potato shelf H1600 F&V	1	-	C211478-
15	End panel right 2-tier potato shelf H1600 F&V	1	-	C211477-

### STANDARD COLOURS



**RAL 7016**  
Anthracite grey  
- 2377



**RAL 7022**  
Umbra grey  
- 2306



**RAL 7024**  
Graphite grey  
- 2303



**RAL 9006**  
White aluminum  
- 2388



**RAL 9010**  
Pure white  
- 2302

Colour code addition number:



## GUSTO | 2-tier | with potato crate | AS 1250 | H1800

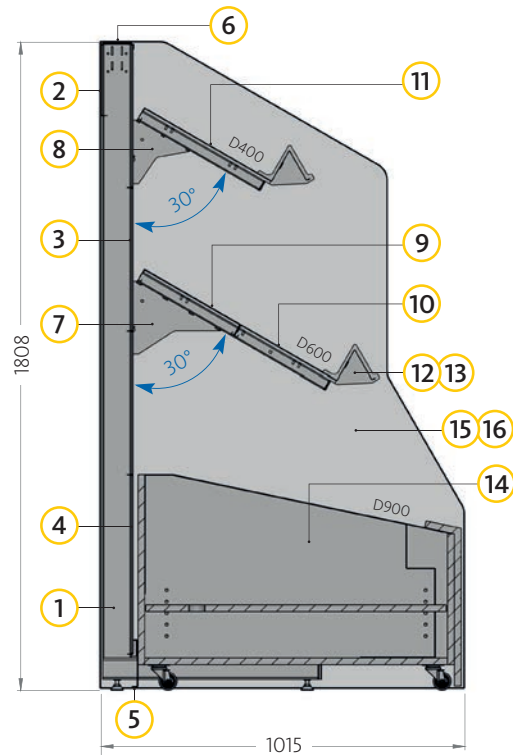

### LIST OF ITEMS

No.	Item description	Number		Item number
		Basic unit	Extension unit	
				<b>AS 1250</b>
1	L-shaped upright H1800 D570 HK25	2	1	C100002-
2	Back panel H200 HK25	1	1	C100014-
3	Back panel H400 HK25	3	3	C001006-
4	Back panel H500 HK25	1	1	C001005-
5	Pallet bumper HK25	1	1	C001099-
6	Cover plate for 80x30 mm HK25	1	1	C100101-
7	Tray frame D600 30° F&V	1	1	OG00005-
8	Tray frame D400 30° F&V	1	1	OG00002-
9	Shelf D300 F&V	1	1	OG00025-
10	Shelf D300 with price rail H100 F&V	1	1	OG00031-
11	Shelf D400 with price rail H100 F&V	1	1	OG00034-
12	Price rail cover H100 right F&V	2	-	OG00017-
13	Price rail cover H100 left F&V	2	-	OG00018-
14	Potato crate L1250 H600 D900 F&V	1	1	C208930-
15	End panel left 2-tier potato shelf H1800 F&V	1	-	C210027L-
16	End panel right 2-tier potato shelf H1800 F&V	1	-	C210027R-

### STANDARD COLOURS

Colour code addition number:

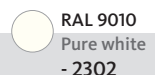
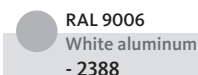
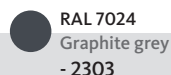
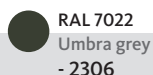
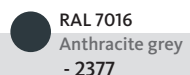

Any other colours upon request!

# F&V TABLE

**BAZAR** | adjustable/mobile | with adjustable front | incl. top piece



Adjustable front!  
35° inclined display

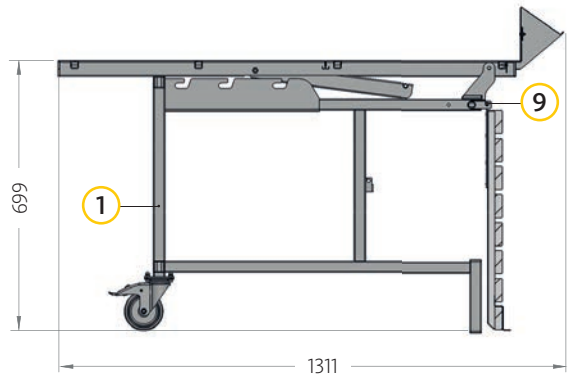
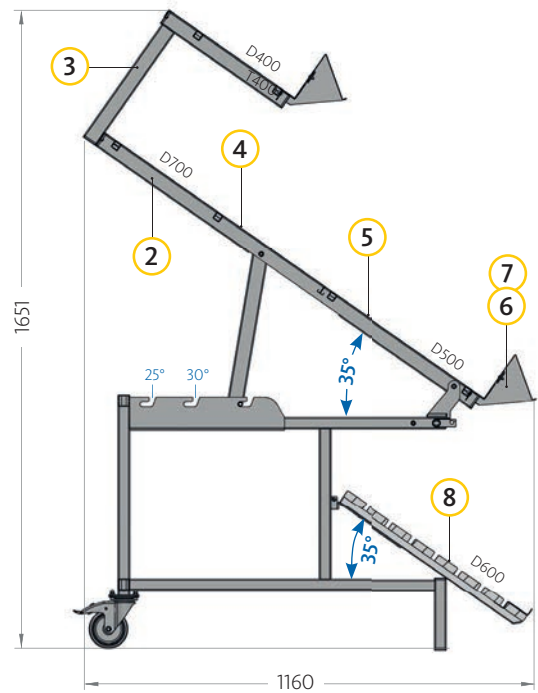

## LIST OF ITEMS

No.	Item description	Number	Item number
			<b>D1200 /B1200</b>
1	Table frame, mobile W1200 D1200 F&V	1	C001499-
2	Shelf, adjustable L1250 D1250 F&V	1	C001433-
3	Top piece D400 F&V	1	C101131-
4	Shelf D700 F&V	1	C001434-
5	Shelf D500 with price rail H100 F&V	1	C001435-
6	Panel for shelf frame right	2	C211791R-
7	Panel for shelf frame left	2	C211791L-
8	Hook-in front panel, D600 and adjustable 35° display	1	C101130-
9	Telescope handle for moving the empty table	1	C211842-
<b>Complete module</b>			<b>C100370-</b>

## STANDARD COLOURS

Colour code addition number:

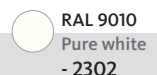
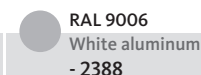
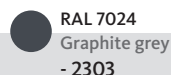
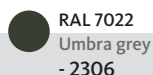
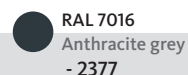

Any other colours upon request!

# F&V TABLE

**BAZAR** | adjustable/mobile | with adjustable front | incl. top piece

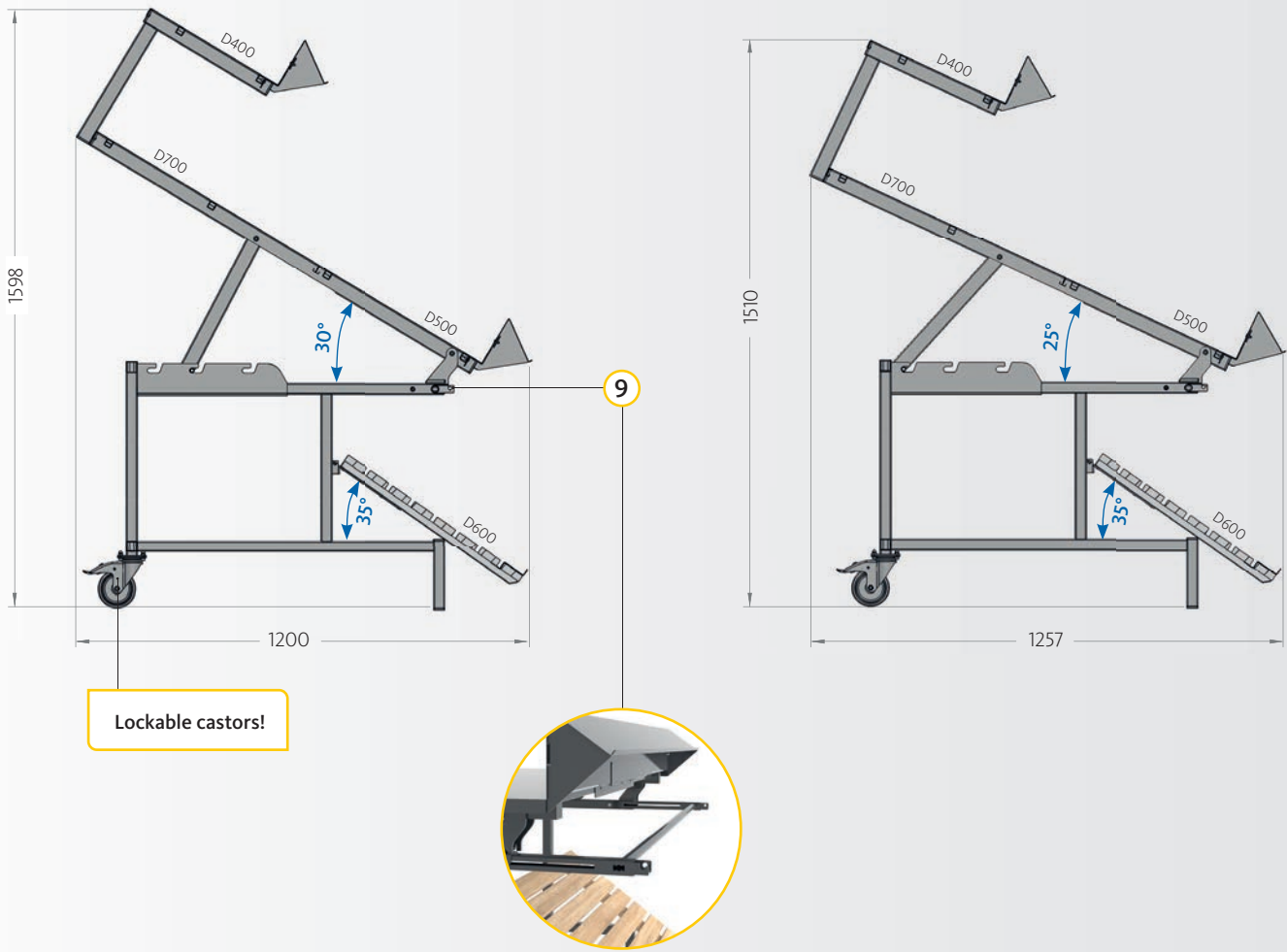

## STANDARD COLOURS

Colour code addition number:

● RAL 7016  
Anthracite grey  
- 2377

● RAL 7022  
Umbra grey  
- 2306

● RAL 7024  
Graphite grey  
- 2303

● RAL 9006  
White aluminum  
- 2388

● RAL 9010  
Pure white  
- 2302

Any other colours upon request!

# F&V TABLE

## BAZAR | adjustable/mobile | with stainless steel shelf



Colour/finish on request

**Optional:**  
Top piece D400 F&V  
C101131- attachable!

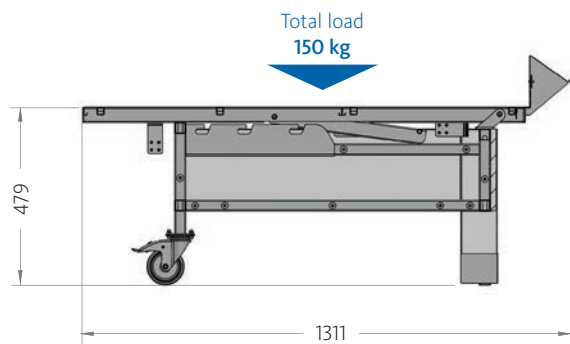
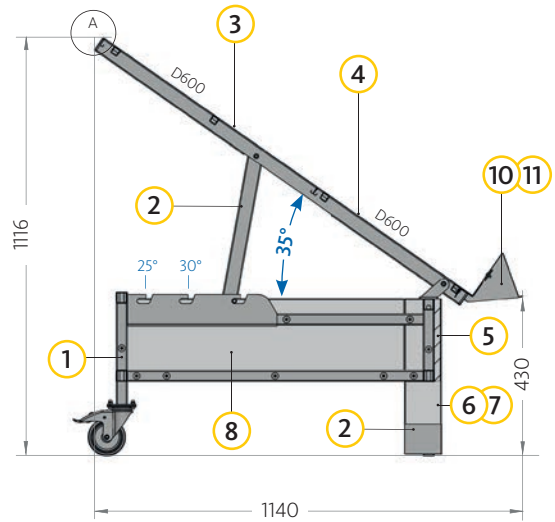
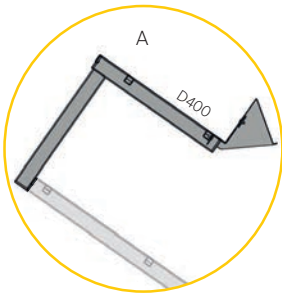

### LIST OF ITEMS

No.	Item description	Number	Item number
			<b>D1200 / B1200</b>
1	Table frame, mobile W1200 D1200 F&V	1	C001426-
2	Shelf, adjustable W1200 F&V	1	C001433-
3	Stainless steel shelf W1200 D600 F&V	1	C001434-
4	Shelf, stainless steel W1200 D600 with price rail H100 F&V	1	C001435-
5	Wooden front panel for table F&V	1	C211686-
6	Wooden base panel right	1	C211687R-
7	Wooden base panel left	1	C211687L-
8	Wooden side panel for table F&V	2	C211688-
9	Base panel stainless steel H100 for table F&V	2	C001437-
10	Panel for shelf frame right	1	C211791R-
11	Panel for shelf frame left	1	C211791L-
<b>Complete module</b>			<b>C101112-</b>
Accessories:			
12	Side panel table <b>suitable only for 35°</b> incline		C211793-



### STANDARD COLOURS

Colour code addition number:

**RAL 7016**  
Anthracite grey  
- 2377

**RAL 7022**  
Umbra grey  
- 2306

**RAL 7024**  
Graphite grey  
- 2303

**RAL 9006**  
White aluminum  
- 2388

**RAL 9010**  
Pure white  
- 2302

Any other colours upon request!

# F&V TABLE

**BAZAR** | adjustable/mobile | with stainless steel shelf

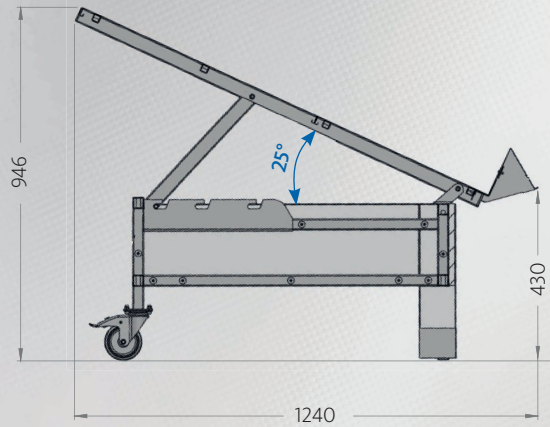
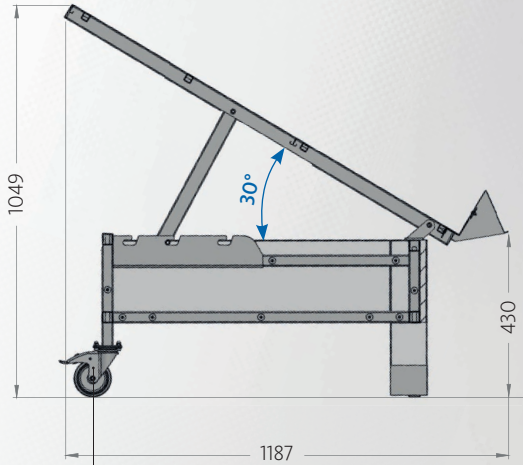

Lockable castors!

# Stainless



## STANDARD COLOURS

Colour code addition number:

● RAL 7016  
Anthracite grey  
- 2377

● RAL 7022  
Umbra grey  
- 2306

● RAL 7024  
Graphite grey  
- 2303

● RAL 9006  
White aluminum  
- 2388

● RAL 9010  
Pure white  
- 2302

Any other colours upon request!

## VARIA | with accessories

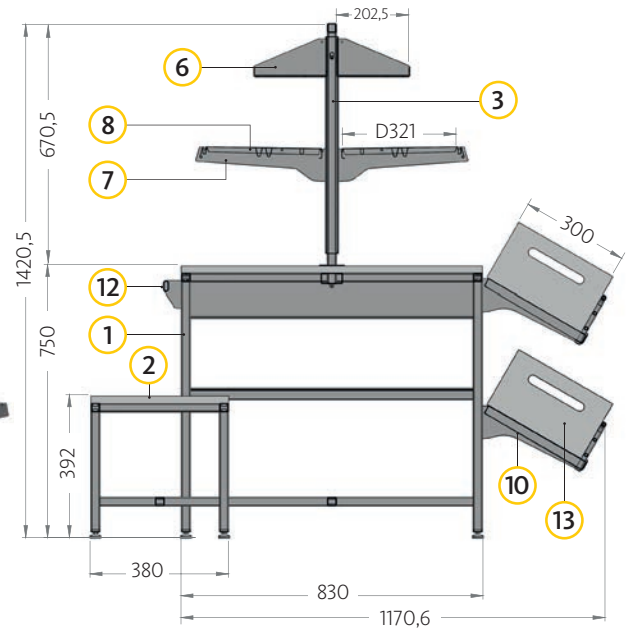

### LIST OF ITEMS

No.	Item description	Item number
1	Table B1280 D830 H750 F&V	C100497-
2	Bank B1200 D380 H392 F&V	C100496-
3	Top piece for table B825 H717 F&V	C100462-
4	Hanging rod F&V	C100461-
5	Back panel flat L800 H600 HK25	C100450-
6	Shelf/tray L800 T200 F&V	C100409-
7	Carrier D300 HK25	C100073-
8	Steel sheet shelf ES groove L800 D300 HK25	C100440-
9	Steel sheet shelf ES groove L1250 D300 HK25	C100189-
10	Shelf, carrier, grid 30° L1250 D300 HK25	C100437-
11	Hanging rod light L800 HK25	C100411-
12	Hanging rod light L1250 HK25	C204554-
13	Fruit crate L400 D300 H175 F&V	C210009

### STANDARD COLOURS

Colour code addition number:



**RAL 7016**  
Anthracite grey  
- 2377



**RAL 7022**  
Umbra grey  
- 2306



**RAL 7024**  
Graphite grey  
- 2303



**RAL 9006**  
White aluminum  
- 2388



**RAL 9010**  
Pure white  
- 2302

# F&V TABLE

## VARIA | with accessories | examples

**Pretty agile:** this promotion table can be quickly redesigned and extended as needed to showcase fruit and vegetables effectively, for instance during asparagus, strawberry or pumpkin season. Cross-selling products can also be displayed here.

The bench/table combination is perfect for customers to stay and taste specialities at their leisure.

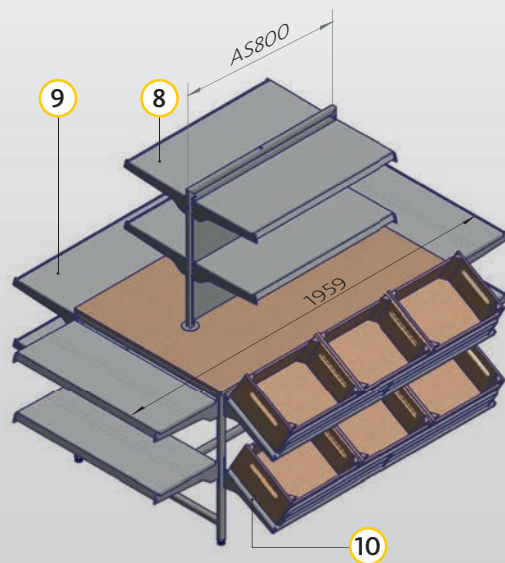
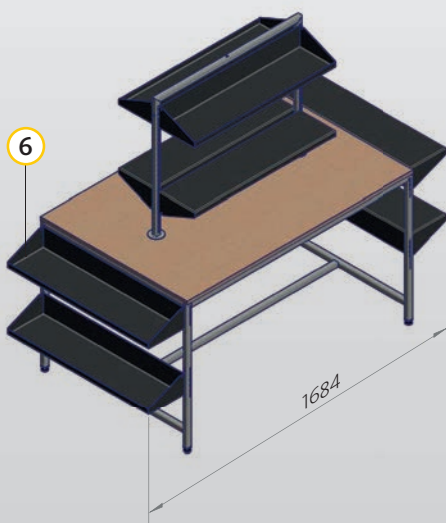
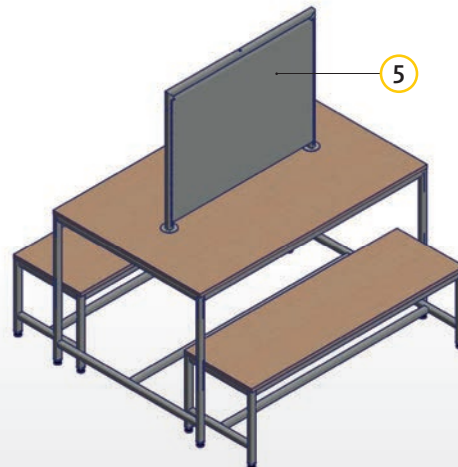
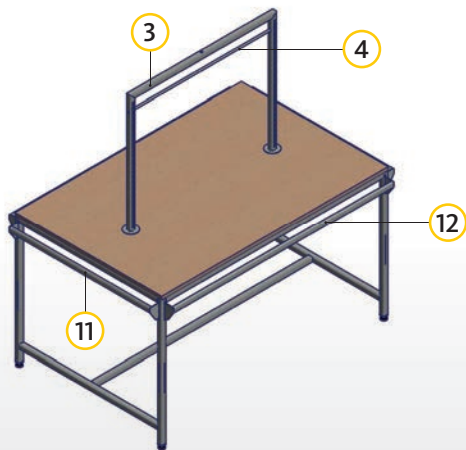
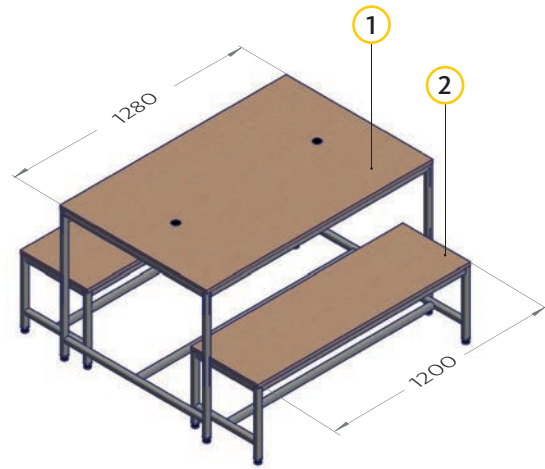

### STANDARD COLOURS

Colour code addition number:

● RAL 7016  
Anthracite grey  
- 2377

● RAL 7022  
Umbra grey  
- 2306

● RAL 7024  
Graphite grey  
- 2303

● RAL 9006  
White aluminum  
- 2388

● RAL 9010  
Pure white  
- 2302

Any other colours upon request!





**BIG OR  
SMALL?  
ALWAYS A  
PERFECT  
DISPLAY!**

# ACCESSORIES

## Wooden front panel

	Description		Width in mm	Height in mm	Item number	
	Wooden front panel for screwing Colour/finish on request 19 mm	Centre	625	390	C208936	
		End	625	390	C208937	
		Centre	1000	390	C208938	
		End	1000	390	C208939	
		Centre	1250	390	C208940	
		End	1250	390	C208941	
		Centre	625	450	C208926	
		End	625	450	C208927	
		Centre	1000	450	SH03452	
		End	1000	450	SH03415	
		Centre	1250	450	SH03416	
		End	1250	450	SH03417	
		Interior corner	Centre	-	390	C211256
			Centre	-	450	SH03418
Exterior corner	Centre	-	450	C209766		

Display D800 for front panel H390 / display D1200 for front panel H450

## Wooden panel over drawer

	Description	Width in mm	Height in mm	Item number
	Wooden panel centre L10   L12 for screwing Colour/finish on request 19 mm	1000	115	C209962-
		1250	115	C209963-

**Please note:** The wooden panel is needed over the drawer as a front cover!

## STANDARD COLOURS

Colour code addition number:

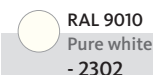
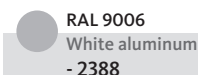
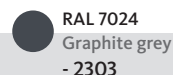
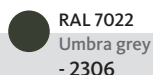
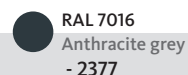

# ACCESSORIES

## Spacer bar

	Description	Width in mm	Depth in mm	Item number
	Spacer bar to hold the wooden panels	625	-	SR00064-
		1000	-	SR00124-
		1250	-	SR00613-

	Description	Width in mm	Display depth	Item number
	Spacer bar to hold the wooden panels for <b>interior corner 45°</b>	20°	800	SR07301-
		30°	1200	OG00075-
	<b>Exterior corner 45°</b>	949	1200	C001548-

**Please note:** you need 2 fixings per axle.

## Drawer

	Description	Width in mm	Depth in mm	Item number
	Drawer box L10   L12 incl. 2 fixed rollers for heavy loads, 2 guide rollers Colour/finish on request Height 346 mm	1000	630	C209956-
		1250	630	C209957-

## Potato crate

	Description	Width in mm	Depth in mm	Item number
	Potato crate Adjustable bottom with divider Colour/finish on request H 600 mm	1000	900	C211648-
		1250	900	C208930-

## Obstkisten

	Beschreibung	Artikelnummer
	Obstkiste <b>Holz</b> Farbe/Dekor auf Anfrage B 490 x T 390 x H 175 mm	C209960-

### STANDARD COLOURS

Colour code addition number:

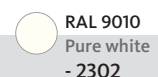
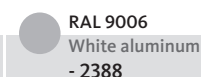
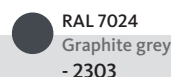
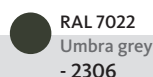
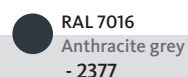

Any other colours upon request!

# ACCESSORIES

## Tray for fruit balance



Description	Shelf	Artikelnummer
Stainless steel tray for fruit balance W 406 x D 369 x H 185 mm	20°	C211660-
	30°	C100372-

## Waste station with scales



Description	Item number
Refuse cabinet with scales and double wing doors W 1000 x D 600 x H 900 mm	C211608-

## Herb ladder with tray



Description	Width in mm	Depth in mm	Item number
Herb ladder 30° H 643 mm	1000	1200	C100417-2000
	1250	1200	C100419-2000
Herb ladder 20° H 643 mm	1250	800	C211651-2000

### STANDARD COLOURS

Colour code addition number:



**RAL 7016**  
Anthracite grey  
- 2377



**RAL 7022**  
Umbra grey  
- 2306



**RAL 7024**  
Graphite grey  
- 2303





**RAL 9006**  
White aluminum  
- 2388





**RAL 9010**  
Pure white  
- 2302

# ACCESSORIES

## Bag roll holder

	Description	Item number
	Bag roll holder W 273 x D 204 x H 318 mm	C100373-
	Bag roll holder "simple" Ø 108 mm/ Ø inner 102 mm, W 280 x H 457 mm	OG00019-

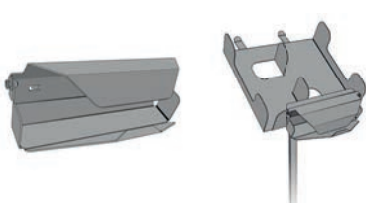
## Paper bag holder

	Description	Item number
	Paper bag holder incl. hook for nets H 978 mm Paper bag sizes: 165 mm x 354 mm and 206 mm x 354 mm	C100811-
	Optional: Bag roll holder for paper bag holder, pluggable Bag roll: W max. 243 mm, Ø max. 90 mm	C100816-
	Integrated paper bag holder incl. hook for nets W 211 x D 382 x H 452 mm Paper bag sizes: 208 mm x 333 mm	C100843-

### STANDARD COLOURS

Colour code addition number:



**RAL 7016**  
Anthracite grey  
- 2377



**RAL 7022**  
Umbra grey  
- 2306



**RAL 7024**  
Graphite grey  
- 2303



**RAL 9006**  
White aluminum  
- 2388



**RAL 9010**  
Pure white  
- 2302

Any other colours upon request!

# ACCESSORIES

## Separator for tray interior corner 45°

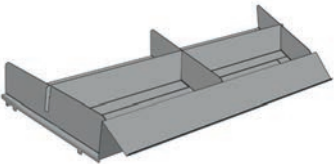
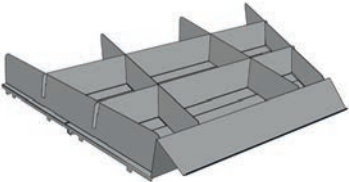
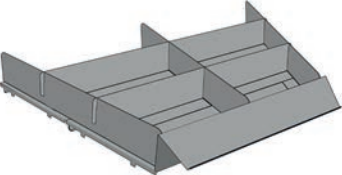
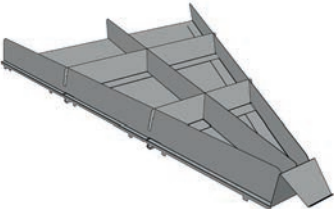
	Description	Depth in mm	Item number
	<p><b>Separator T4</b> IC45° stainless steel multi-part for 30° fits with:</p> <p><b>Cascade</b>   interior corner   3-tier   with tray (p.43)</p>	400	<b>C100883-set</b>
	<p><b>Separator T6</b> IC45° stainless steel multi-part for 30° fits with:</p> <p><b>Vegano</b> interior corner 2-tier with tray (p. 35)</p> <p><b>Vegano Plus</b> IE, 2-stufig mit Auflage (S. 39)</p> <p><b>Vegano Plus</b> interior corner 2-tier with tray and mirror (p.41)</p> <p><b>Cascade</b> interior corner, 3-tier with tray (p.43)</p>	600	<b>C209513-set</b>
	<p><b>Separator T8</b> IC45° stainless steel multi-part for 20° fits with:</p> <p><b>Vegano</b> interior corner 2-tier with tray (p. 35)</p> <p><b>Cascade</b> interior corner, 3-tier with tray (p. 43)</p>	800	<b>C100881-set</b>
	<p><b>Separator T12</b> IC45° stainless steel multi-part for 30° fits with:</p> <p><b>Verde</b> interior corner, 1-tier with tray (p. 25)</p> <p><b>Verde</b> interior corner 1-tier with tray and mirror (p. 27)</p> <p><b>Vegano Plus</b> interior corner 2-tier with tray (p. 39)</p> <p><b>Vegano Plus</b> interior corner 2-tier with tray and mirror (p. 41)</p>	1200	<b>C209512-set</b>

### STANDARD COLOURS

Colour code addition number:

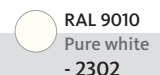
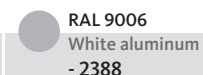
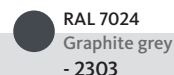
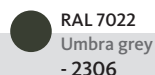
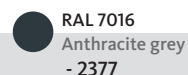

# ACCESSORIES



## Divider for tray exterior corner 45°

	Description	Depth in mm	Item number
	<b>Divider T6</b> EC45° stainless steel multi-part fits with: <b>VEGANO PLUS</b> EC, 2-tier with tray (p. 39)		
	for 20°	600	<b>C101149-set</b>
	for 30°	600	<b>C213077-set</b>
	<b>Divider T12</b> EC45° stainless steel multi-part fits with: <b>VEGANO PLUS</b> EC, 2-tier with tray (p. 39)		
	for 20°	1200	<b>C101152-set</b>
	for 30°	1200	<b>C213076-set</b>

### STANDARD COLOURS

Colour code addition number:

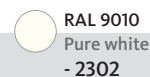
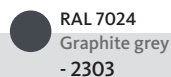
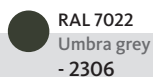
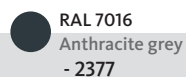

Any other colours upon request!

# ACCESSORIES

## Corner case with lid

	Description	W x D in mm	Height in mm	Item number
	Corner case with particle board lid Colour/finish on request	1010 x 1010	1600	C209988-
		1310 x 1310	1600	C209989-

	Corner case with particle board lid Colour/finish on request	1010 x 1010	1800	C209985-
		1310 x 1310	1800	C209984-

## Corner case 2-tier with lid for special product presentation, e.g. herb pots

	Description	W x D in mm	Height in mm	Item number
	Corner case with particle board lid <b>2-tier</b> Colour/finish on request	1310 x 1310	1600	C209986-

	Corner case with particle board lid <b>2-tier</b> Colour/finish on request	1310 x 1310	1800	C209987-
---	--	-------------	------	----------

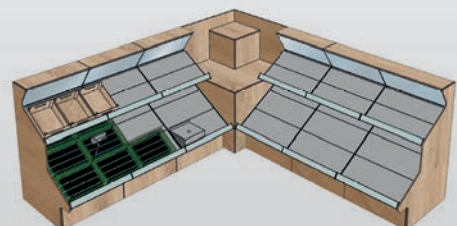
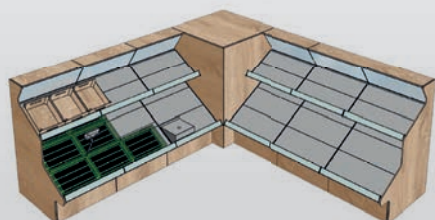
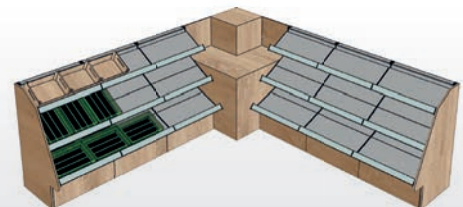
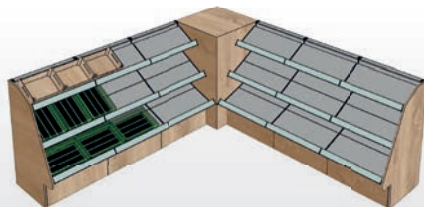



# ACCESSORIES

## Mobile pedestal



### Description

Mobile pedestal with stainless steel top  
colour/finish on request  
W 1200 x D 800 x H 555 mm

### Item number

C212171-



# ACCESSORIES



## Rectangular basket | made of polyrattan

No.	Description	Dimensions in mm	Colour	Item number
1	Basket, rectangular	30 x 30 x 12	light brown	C210939
			dark brown	C210940
2	Basket, rectangular	40 x 30 x 12	light brown	C210941
			dark brown	C210942
3	Basket, rectangular	60 x 30 x 12	light brown	C210943
			dark brown	C210944
4	Basket, rectangular	60 x 40 x 12	light brown	C210945
			dark brown	C210946

## Basket round | made of cooked willow

No.	Description	Dimensions in mm	Colour	Item number
5	Basket, round	Ø 40   Height 12	Cooked willow	C210947
6	Basket, round	Ø 50   Height 15	Cooked willow	C210948
7	Basket, round	Ø 60   Height 16	Cooked willow	C210949



# ACCESSORIES



## Beach chair with display basket top | made of polyrattan

No.	Description	Dimensions in mm	Colour	Item number
8	Top display basket	Ø 45   Height 12	dark brown	C210950
9	Beach chair	Ø 45   Height 49	dark brown	C210951
10	Top display basket	Ø 49   Height 17	light brown	C210952
			dark brown	C210953
11	Beach chair	Ø 40   Height 50	light brown	C210954
			dark brown	C210955
12	Top display basket	Ø 60   Height 20	light brown	C210956
			dark brown	C210957
13	Beach chair	Ø 50   Height 60	light brown	C210958
			dark brown	C210959
14	Beach chair	Ø 50   Height 50	light brown	C210960
15	Beach chair	Ø 52   Height 60	light brown	C210961
16	Top display basket	Ø 70   Height 19	light brown	C210962
17	Beach chair	Ø 60   Height 70	light brown	C210963



# ACCESSORIES

## FLOWER SHELF | with accessories

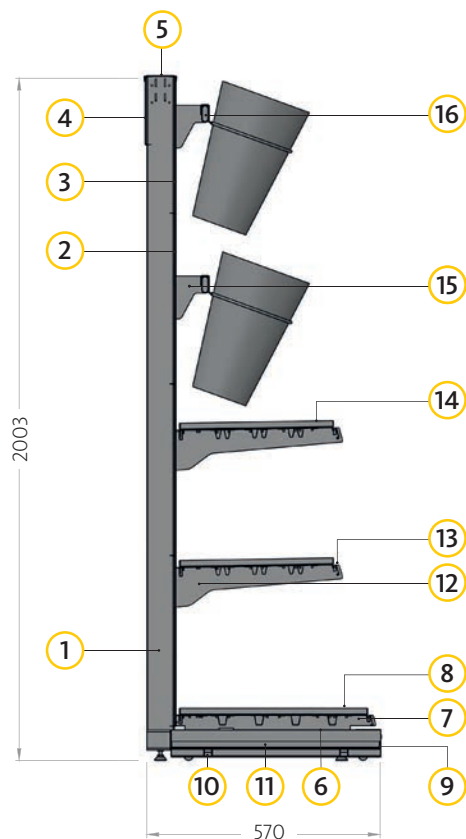

### LIST OF

No.	Item description	Number	Item number	
			AS 1000	AS 1250
1	L-shaped upright H2000 D570 HK25	2	C100451-	C100451-
2	Back panel H500 HK25	3	C001008-	C001005-
3	Back panel H400 HK25	1	C001009-	C001006-
4	Back panel H200 HK25	1	C100020-	C100014-
5	Cover plate for 80x30 mm HK25	1	C100100-	C100101-
6	Foot carrier D570	2	C001041-	C001041-
7	Shelf D570 4UZ HK25	1	X911560-	X911570-
8	Flower tray H20 D570 HK25	1	C100921-	C100924-
9	Base foot drawer* D570 AS HK25	1	C100994-	C100718-
10	Rack for flower tray HK25	1	C100995-	C100993-
11	Flower tray stainless steel for base foot drawer HK25	1	C100996-	C100992-
12	Carrier D470 HK25	4	C100003-	C100003-
13	Shelf D470 HK25	2	X911460-	X911470-
14	Flower tray H20 D470 HK25	2	C100920-	C100923-
15	Standard rail flowers HK25	2	C100998-	C100997-
16	Holder for flower bucket HK25 (AS1000 = 6 items)	8	C211435-	C211435-
17	Irrigation mat (not included in the illustration)	4	C211382-	C211382-

\*Base foot drawer can be drawn out to a total depth of 1000 mm!

### STANDARD COLOURS



**RAL 7016**  
Anthracite grey  
- 2377



**RAL 7022**  
Umbra grey  
- 2306



**RAL 7024**  
Graphite grey  
- 2303



**RAL 9006**  
White aluminum  
- 2388



**RAL 9010**  
Pure white  
- 2302

Colour code addition number:

# ACCESSORIES

## Flower tray



Description	Width in mm	Depth in mm	Item number
Flower tray Stainless steel, polished welded watertight H 20 mm	1000	470	C100920-2120
	1000	570	C100921-2120
	1250	470	C100923-2120
	1250	570	C100924-2120

## Irrigation mat



Description	Width in mm	Depth in mm	Item number
Irrigation mat, fleece Black double-layer	1000	450	C211610
	1000	550	C211611
	1250	550	C211382

## Flower bucket



Description	Item number
Flower bucket for flower shelf zinc-plated Height 401 mm Ø top 273 mm/ Ø bottom 165 mm	C211476-2156



# KIND 4 stores

pure shopfitting

KÖNIG | HARRES | OTTOKIND | ZOK

HARRES Metall-design GmbH

Max-Eyth-Straße 10 | 59581 Warstein | Germany

Telephone +49 (0) 2902 9775-0 | [www.KIND4stores.com](http://www.KIND4stores.com) | [info-DE@KIND4stores.com](mailto:info-DE@KIND4stores.com)